

# [ADESSO Xtream P400 Wireless Headphone User Manual](#)

## [Manualsum](#), simplified manuals

### Table of Contents

- [ADESSO Xtream P400 Wireless Headphone User Manual](#)
  - [DESCRIPTION](#)
  - [INTRODUCTION](#)
    - [Features:](#)
    - [Requirements:](#)
  - [CONTENTS](#)
  - [LIMITED WARRANTY](#)
  - [SUPPORT](#)

## **ADESSO Xtream P400 Wireless Headphone User Manual**

ADESSO Xtream P400 Wireless Headphone User Manual

FCC id: [2ACFQ-XTREAMP400](#)

Xtream P400 Bluetooth Multimedia Headset with Charging Dock



ADESSO<sup>®</sup>

Model: Xstream P400

[Manualsum](#)

# DESCRIPTION

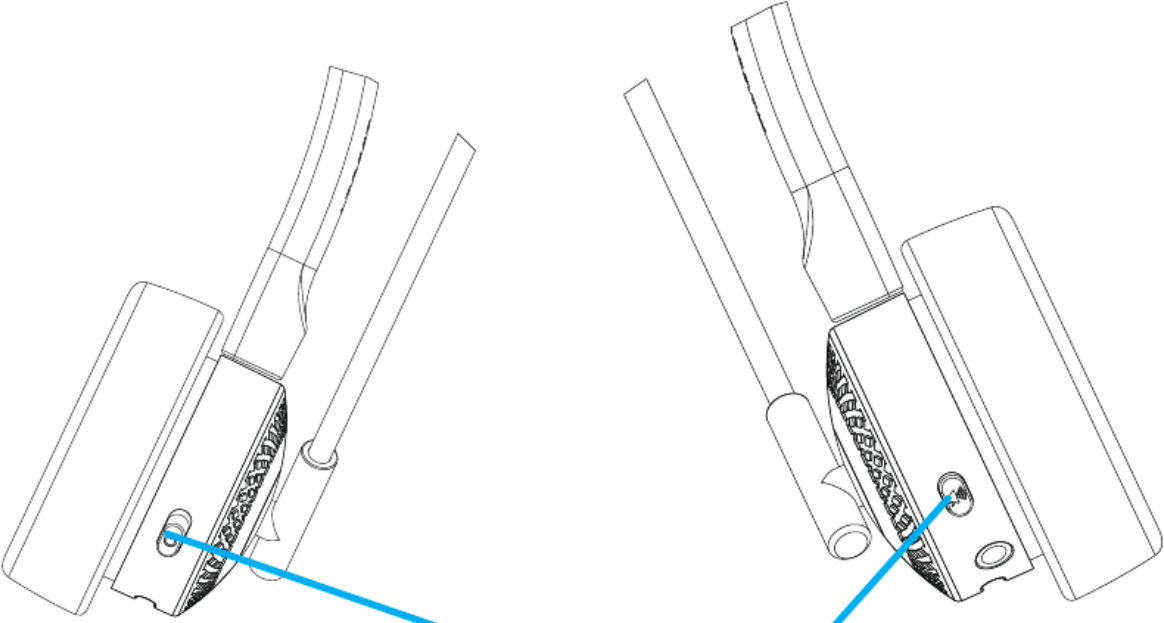

Power Switch

Volume Button

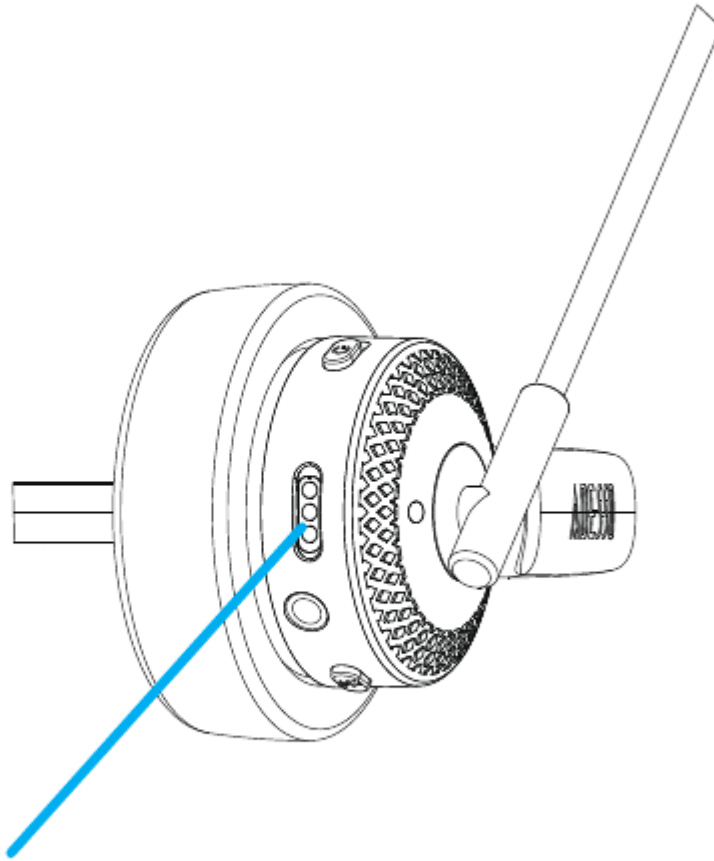

**Charging Port**

## **INTRODUCTION**

The Adesso Xstream P40 is Multimedia Bluetooth Headset with Microphone that's lightweight, and designed for office use. Bluetooth connectivity ensures high-quality audio, long battery life, and support for a variety of devices.

### **Features:**

- **Connection:** Bluetooth 5.0
- **Wireless Range:** > 32 feet (10m)
- **Built-in Mic:** Omnidirectional
- **Speaker Driver:** 23mm
- **Battery:** 3.7V, 130mAh
- **Charging Time:** 2 Hours
- **Talk Time:** Up to 8 Hours
- **Stand by:** Up to 100 Hours
- **Product Dimensions:** 6.4x56x1.9"
- **Headset Weight:** 0.11 lb
- **Charge Base Weight:** 0.39 lb

## Requirements:

Bluetooth enabled device

## CONTENTS



Xtream P400

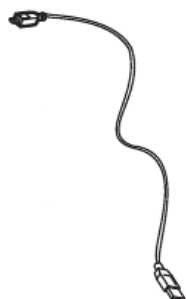

Charging Cable



Charging Base



User Guide

## LIMITED WARRANTY

Adesso provides a one year limited warranty for all of its products against defects in material and workmanship.

During this period, Adesso will repair or replace any product which proves to be defective. However, Adesso will not warranty any product which has been subject to improper freight handling, shipping abuse, neglect, improper installation or unauthorized repair. The warranty will not cover products installed with components not approved by Adesso and products where the sealed assembly trace has been broken.

If you discover a defect, Adesso will, at its option, repair or replace the product at no charge to you provided you return it during the warranty period with freight charges pre-paid to Adesso. Before returning any product, you must obtain a Return Merchandise Authorization number (RMA). This RMA # must be clearly marked on the outside of the package you are returning for warranty service. Be certain to also include your name, shipping address (no PO Boxes), telephone number, and a copy of the invoice showing proof of purchase in the package.

## SUPPORT

- **FAQs:** <https://www.adesso.com/fags/>
- **Email Support:** [support@adesso.com](mailto:support@adesso.com)
- **Telephone Support:** (800) 795-6788
- 9:00AM to 5:00PM PST MONDAY - FRIDAY
- [www.adesso.com](http://www.adesso.com)