

[ARTIKA Vance LED Pendant Light User Manual](#)

[Manualsum](#), simplified manuals

Table of Contents

- [ARTIKA Vance LED Pendant Light User Manual](#)
 - [STEP-BY-STEP INSTALLATION](#)
 - [CAUTION](#)
 - [MOUNTING BRACKET INSTALLATION](#)
 - [WIRE CONNECTION](#)
 - [LIGHT FIXTURE INSTALLATION](#)
 - [WARRANTY](#)

ARTIKA Vance LED Pendant Light User Manual

ARTIKA Vance LED Pendant Light User Manual

Model: PDT-VNC-BL

([2AUHG-PDT-VNC](#))

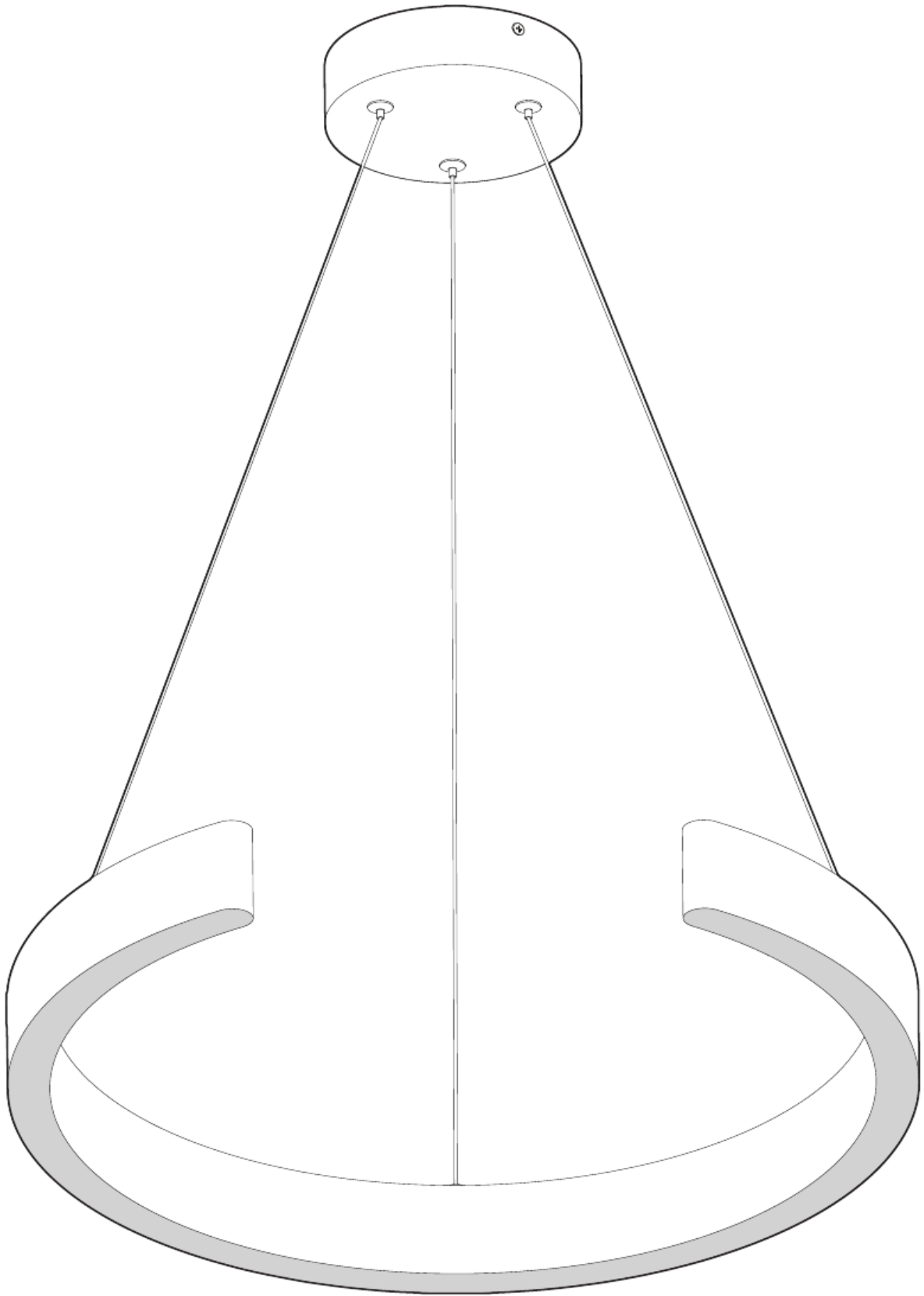

INCLUDED HARDWARE
MATÉRIEL INCLUS
HERRAMIENTAS INCLUIDAS

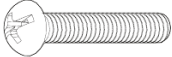
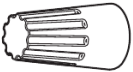
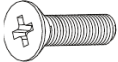
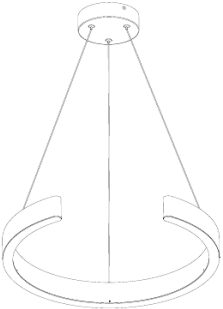
ITEM PIÈCE PIEZA	DESCRIPTION DESCRIPTION DESCRIPCIÓN	QUANTITY QUANTITÉ CANTIDAD
A 	Mounting bracket Support de montage Soporte de montaje	× 1
B 	Junction box screw Vis de boîtier de raccordement Tornillo de caja de conexiones	× 2
C 	Wire connector Capuchon de connexion Conector de cable	× 3
D 	Canopy screw Vis de la base Tornillo de dosel	× 2 +1 extra
E 	Light fixture Luminaire Luminaria	× 1

WHAT YOU WILL NEED
VOUS AUREZ BESOIN
LO QUE NECESITARÁ

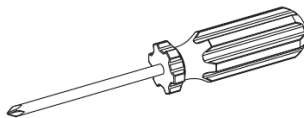

Screwdriver
 Tournevis
 Destornillador  2

STEP-BY-STEP INSTALLATION

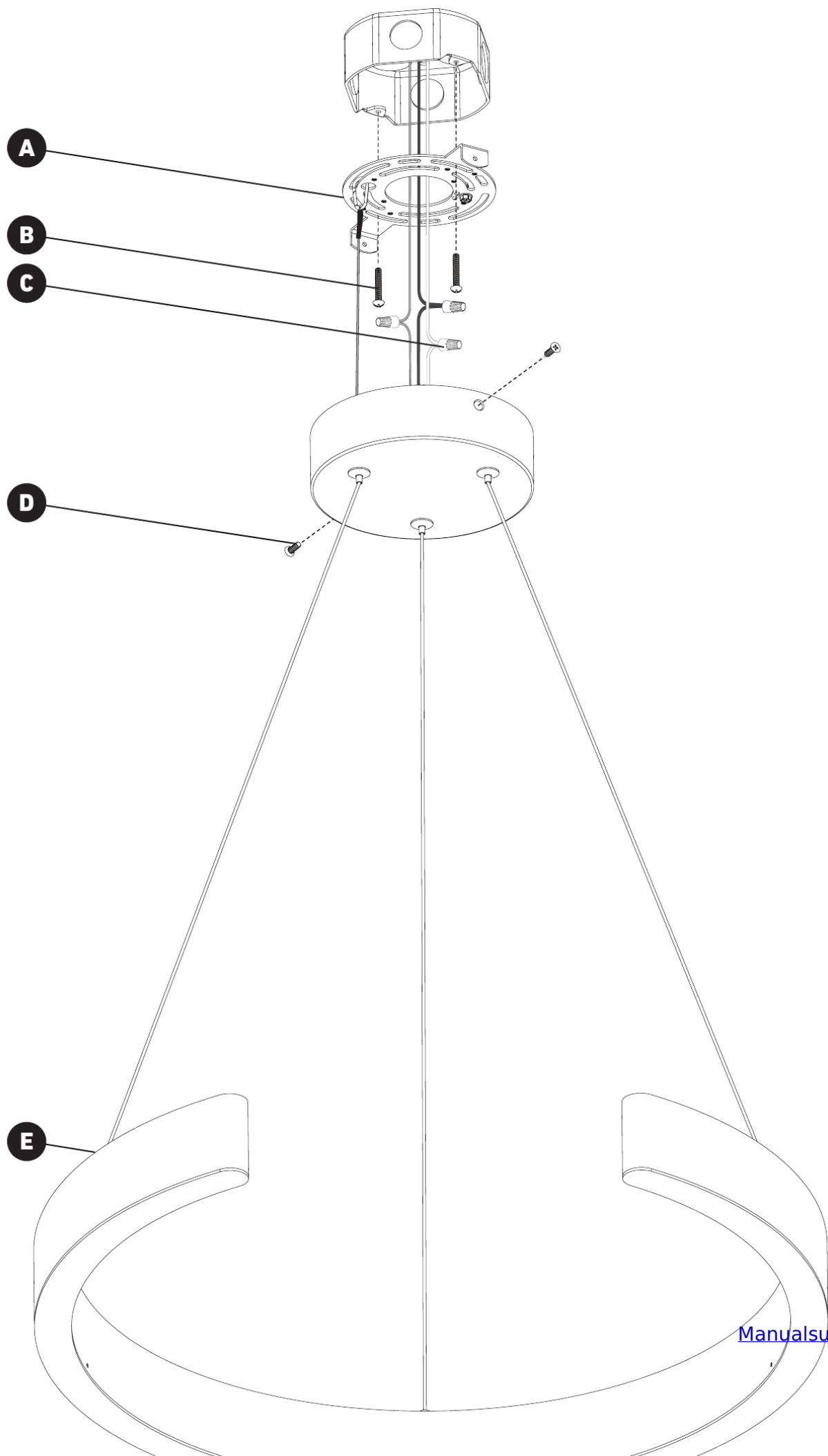

CAUTION

WARNING:

Risk of electrical shock. Turn off the power at the breaker panel.

Switch off the main electrical supply from the fuse box/circuit breaker before installing the unit or doing any maintenance.

Do not use outdoors.

CAUTION

If using a dimmer, it must be LED compatible.

IMPORTANT

The installer and/or user must read, understand and follow these instructions before installing the product. This product must be properly installed before it is used. If instructions are not followed, the manufacturer will not be held responsible for any problems or product malfunction. Failure to follow installation and/or operating instructions voids the warranty.

We recommend that this product be installed by a certified electrician. In some states or provinces, it is a legal requirement for this type of product to be installed by a certified electrician, according to the electrical and building codes in effect in the region where the unit is used.

HEIGHT ADJUSTMENT

NOTE: Making any major adjustments to the height of the light fixture before installation is recommended.



Retract the wire
Raccourcir le fil
Acortar el cable

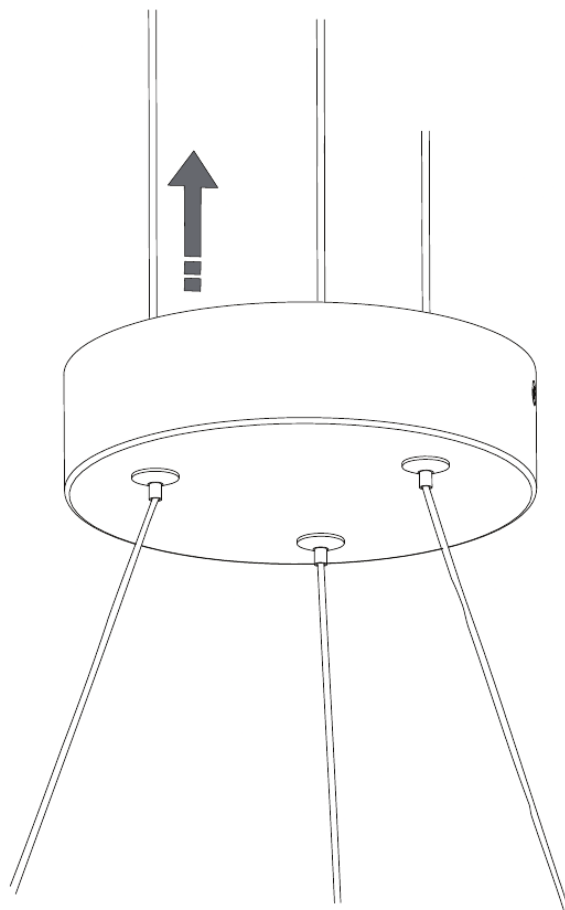

Extend the wire
Allonger le fil
Alargar el cable

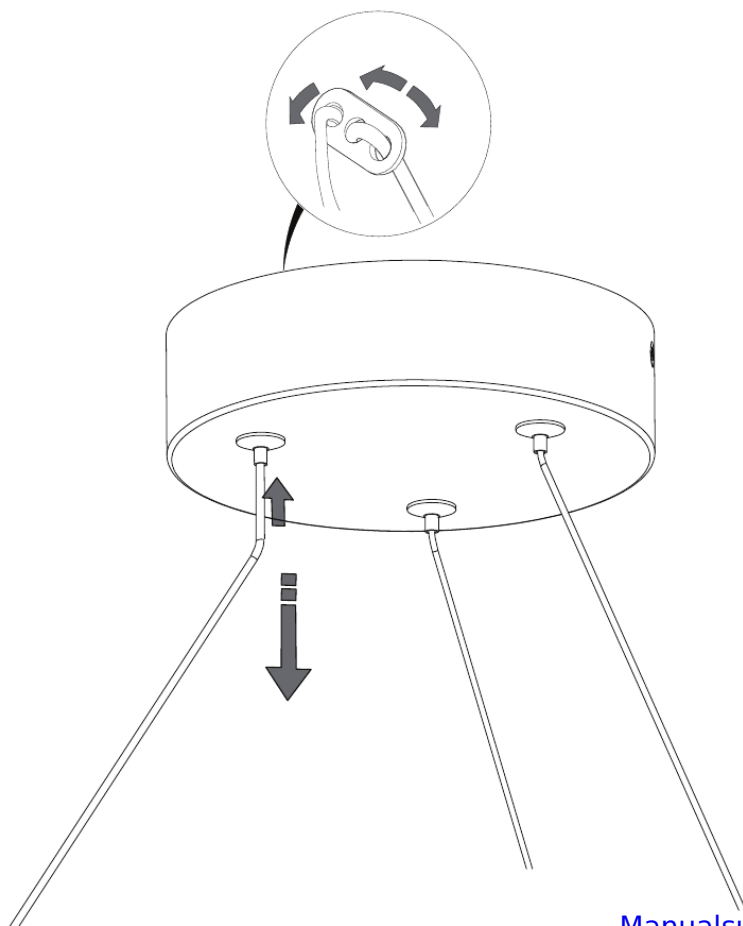

MOUNTING BRACKET INSTALLATION

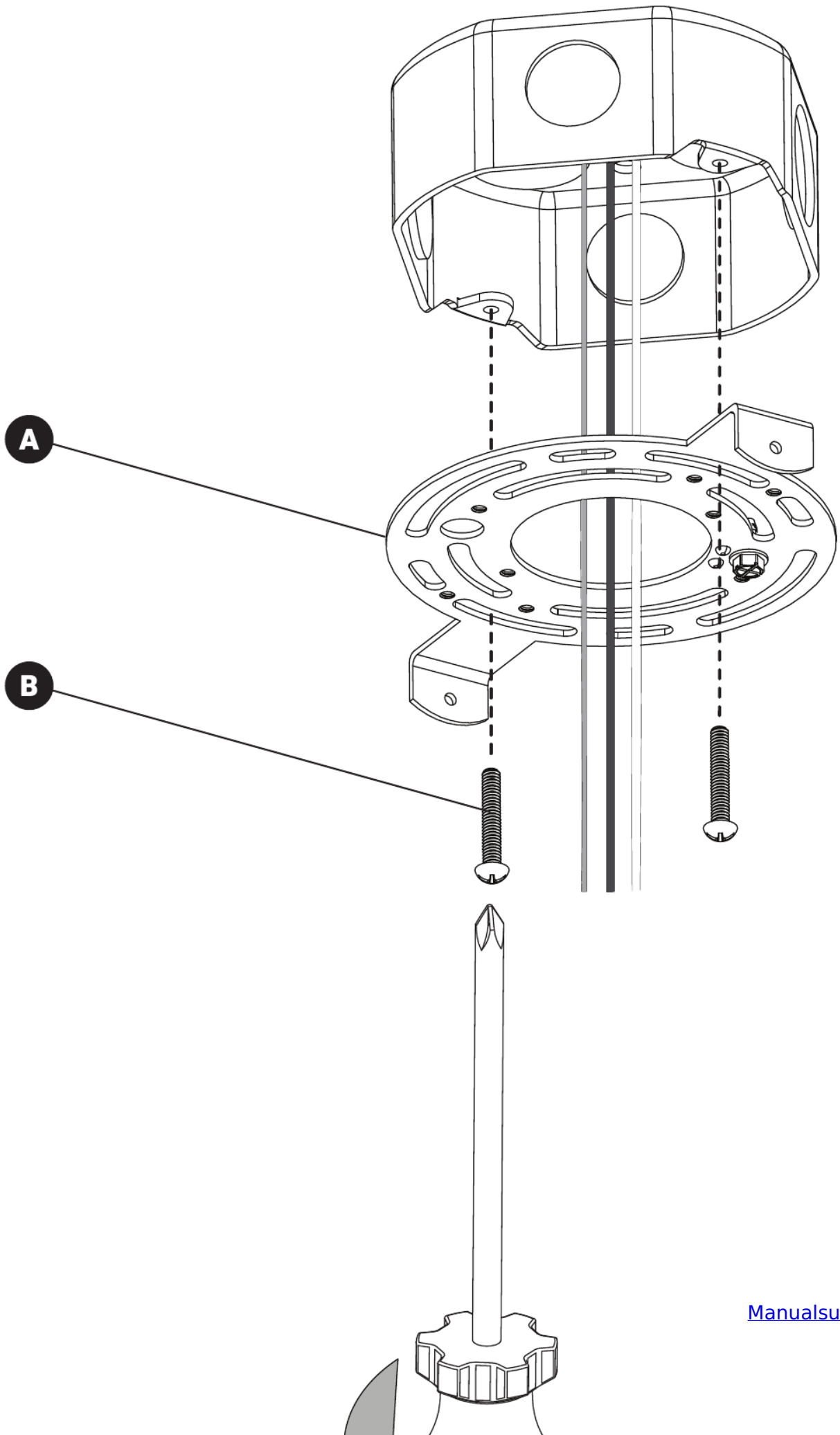

WIRE CONNECTION

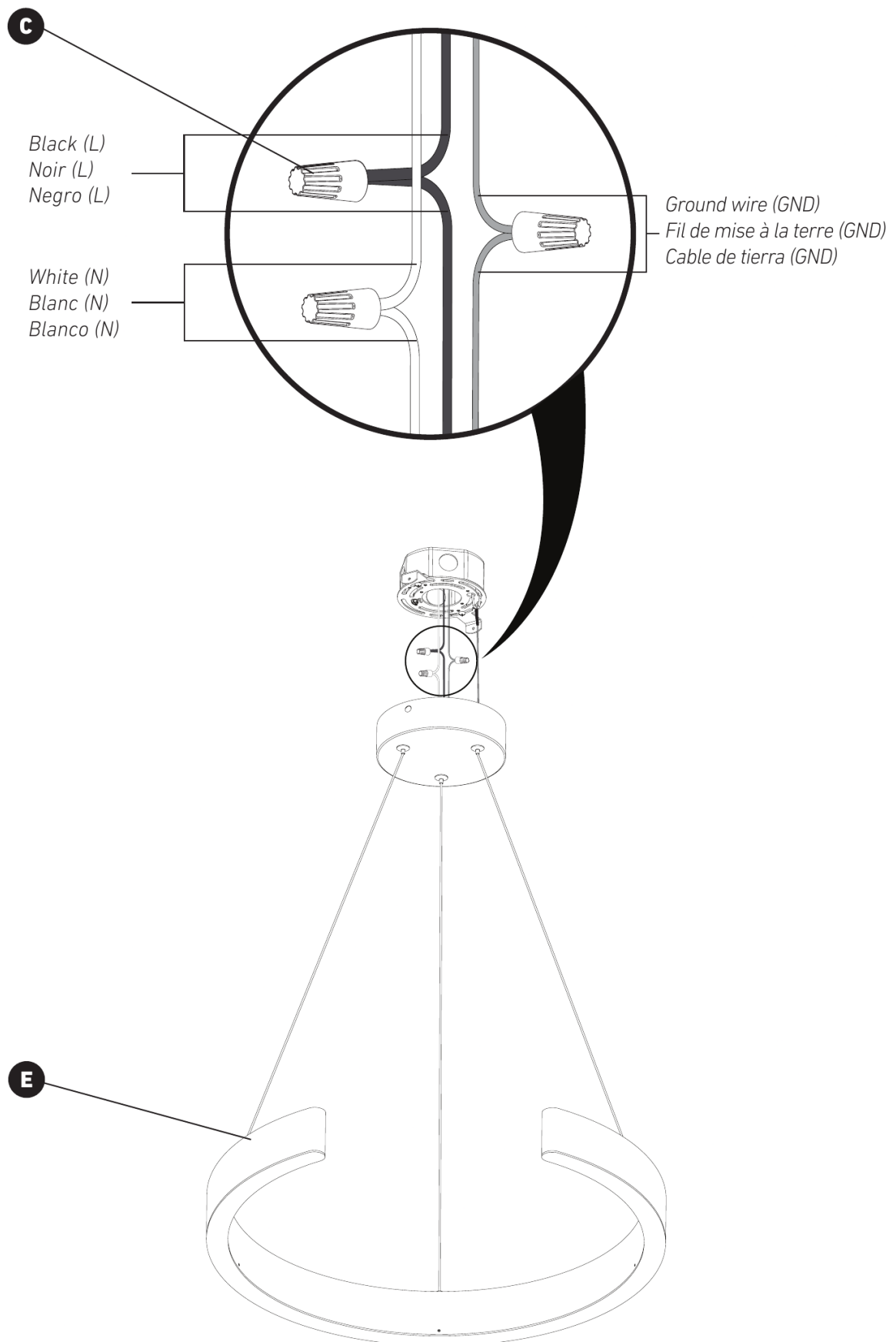

LIGHT FIXTURE INSTALLATION

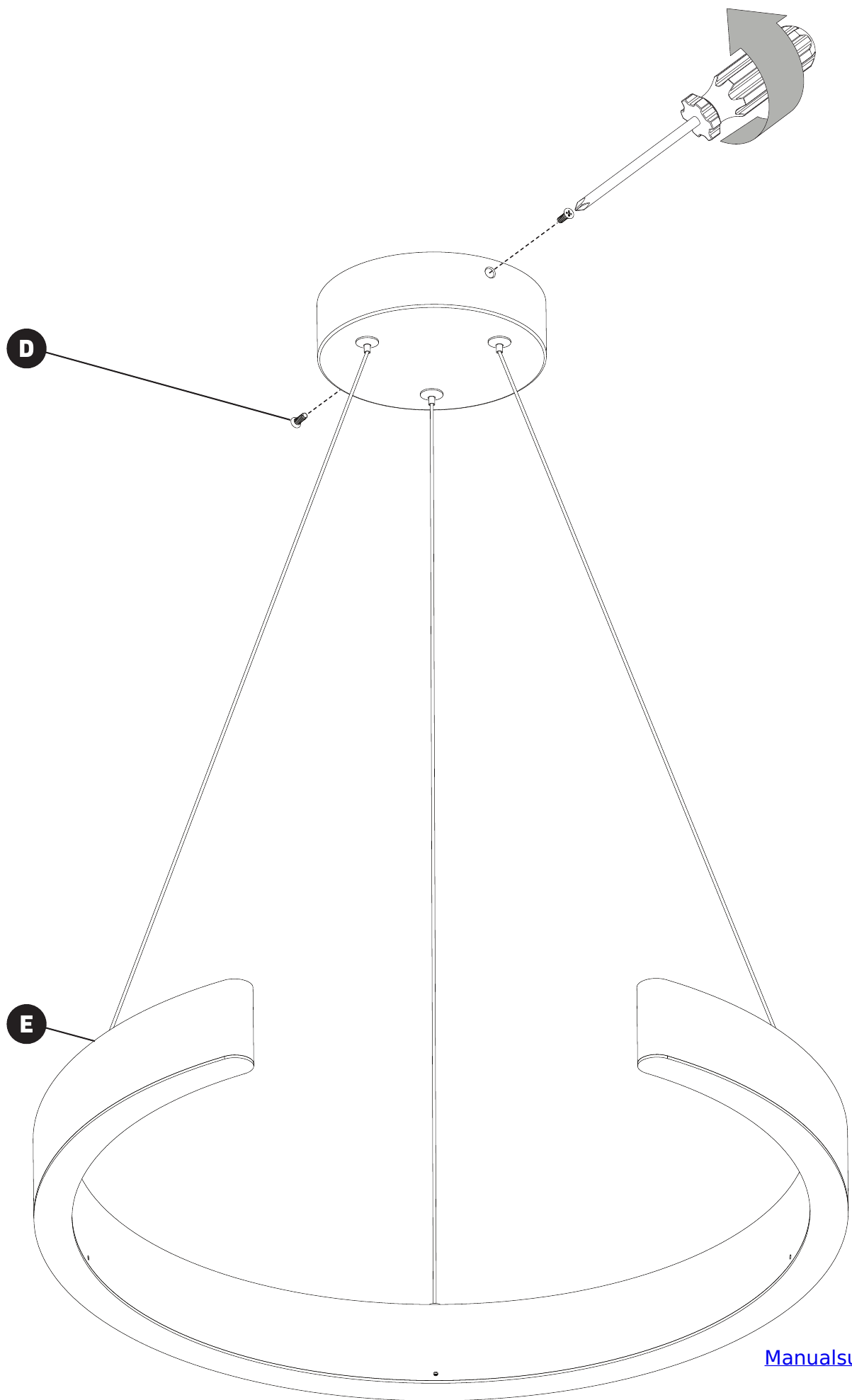

SELECTABLE WHITE TECHNOLOGY

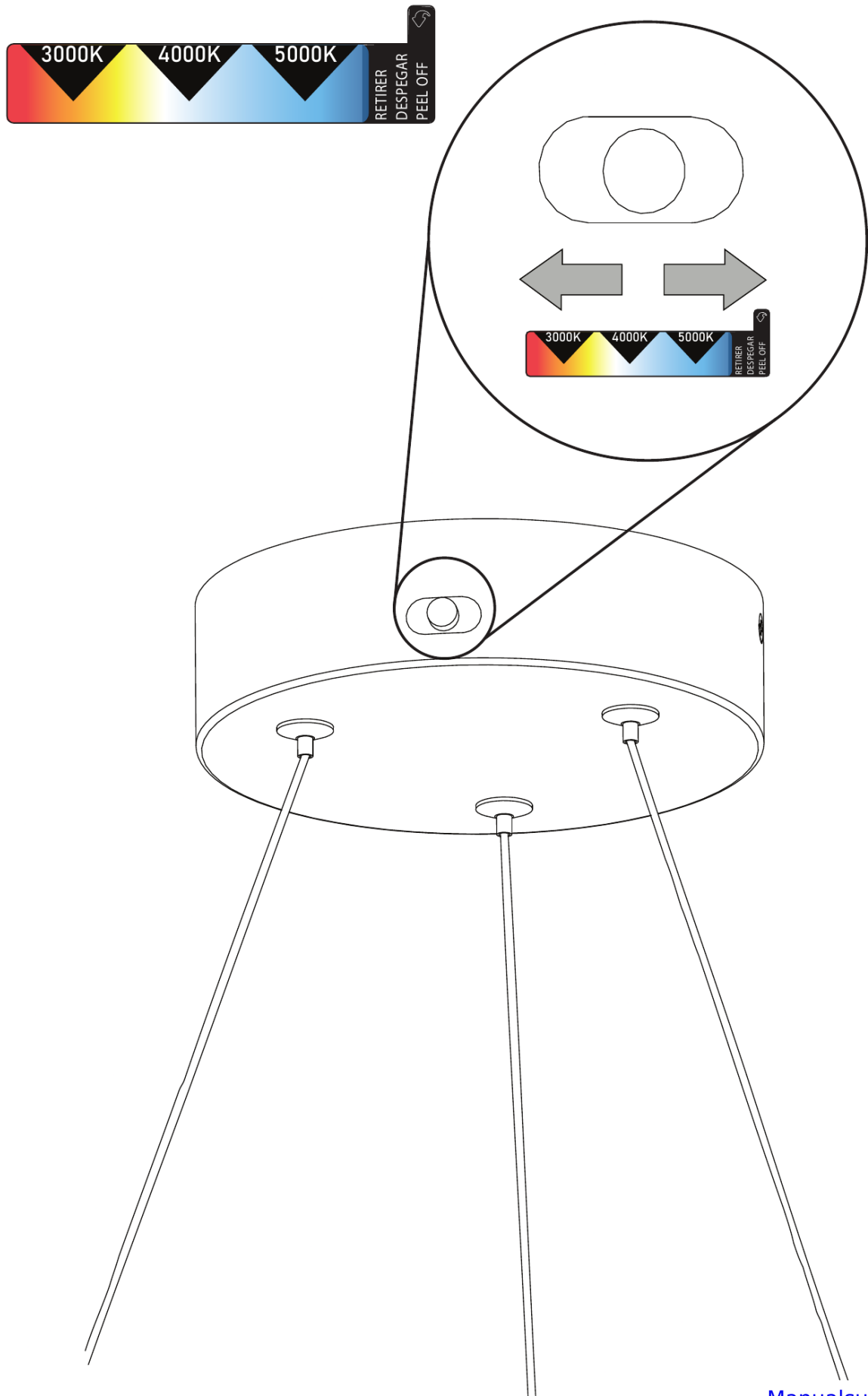

WARRANTY

Artika For Living Inc. is proud to offer you a three-year (3) limited warranty on manufacturing defects from the date of purchase for residential use only. The warranty is extended to the original owner in the US, Canada, Mexico, the UK, Iceland, France and Spain and is non-transferable. It does not apply to retailers, commercial applications or establishments. The original sales receipt is required for all warranty claims. The remedy under this limited warranty shall be product or part replacement at Artika's discretion as provided herein and may not exceed the original purchase price.

This warranty is valid only on products installed in accordance with the building code and laws in effect in the region where the unit is being used, as well as in accordance with the provided instruction manual. It does not cover products installed incorrectly or subjected to abnormal use. You may be required to return product(s) or component part(s) for inspection and verification.

Normal wear and tear, misuse, negligence, vandalism, improper maintenance (surface damage due to chemical interaction or cleaning agents including, but not limited to, scouring pads, use of cleaners containing abrasives, alcohol or other organic solvents), improper handling, accident, abuse, fire, flood, theft, acts of God, neglect, or alteration of the product will not be covered under this limited warranty. It excludes any accessories that accompany the product including, but not limited to bulbs or batteries.

This warranty does not cover handling, labour, transportation, or any other cost associated with the installation or replacement of the product. This limited warranty is valid in the country of purchase and for products sold by Artika authorized retailers only. Artika for Living Inc. will not be held responsible for any direct or consequential damages or injuries related to the use of this product arising from improper use or installation of this product.

Please visit www.artika.com to discover more about Artika for Living Inc.

Artika For Living Inc. 1756, 50^e Avenue Montréal (Lachine), Québec Canada H8T 2V5

1-866-661-9606

support@artika.com

www.artika.com



[Manualsum](#)