

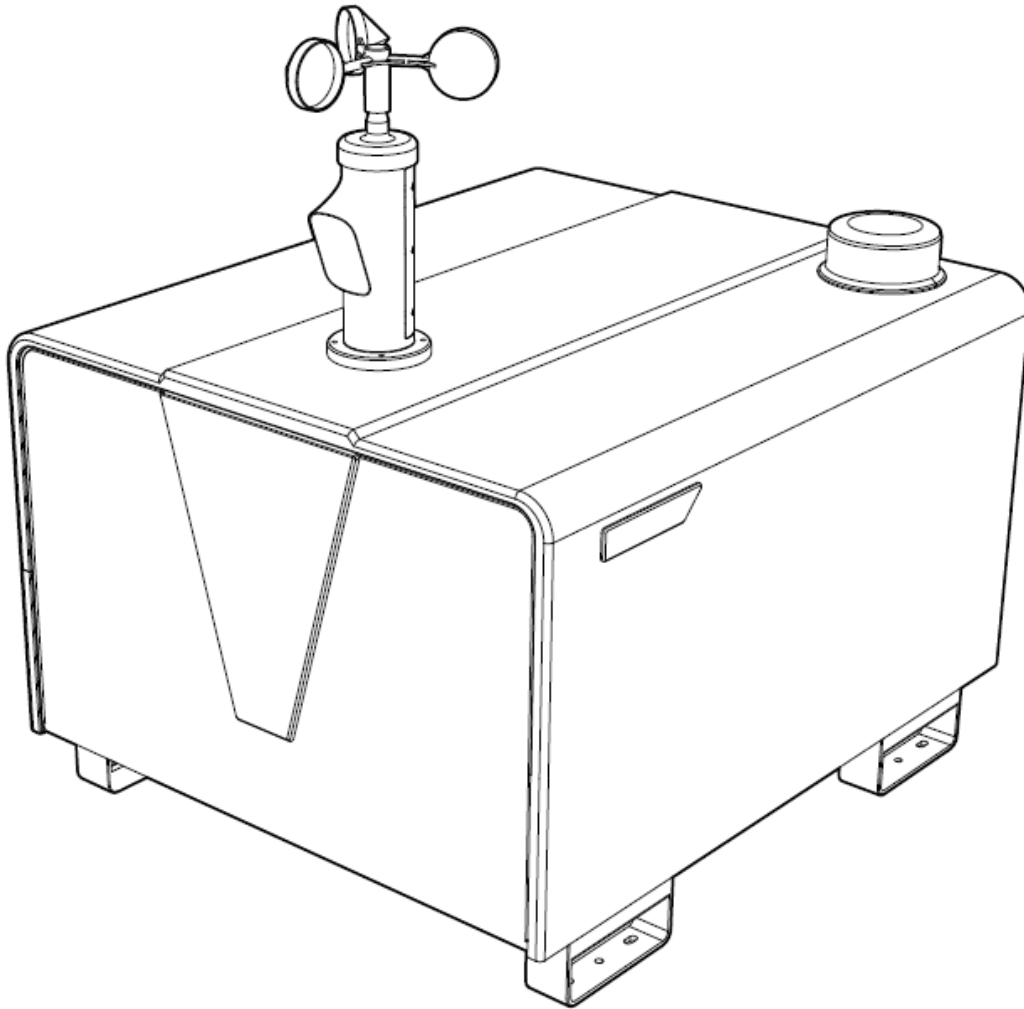

GDU-Tech Co., Ltd.



K03 *Docking Station*

User Manual (v1.2) 2024.09

Table of Contents

Instructions	1
Warning	1
Disclaimer.....	1
Product Overview	2
Introduction.....	2
Highlights.....	2
Docking Station	3
Component List.....	3
Debug Box	4
Emergency Stop.....	4
Door	5
Docking Station LED Indicator	5
Docking Station Environment Perception	6
Monitoring camera and fill light.....	6
Anemometer	6
Rain gauge	7
Water immersion sensor	7
Light sensor	8
Landing Pad	8
Air Conditioning System	9
Docking Station RTK	9
Docking Station Protection Level.....	9
Instructions for UVER	10
System Login	10
Docking Station Control	10
Docking Station List	11
Aircraft List.....	11
Task List	12
Aircraft Control.....	12
Route Management	13
Add a new route	13
View route	13
Delete route	13
Task Management.....	14
Create a new task.....	14
View tasks	15
Delete task	15
Data Center	15
View task results package	15
Delete mission results package.....	16
Appendix	17

Instructions

Warning

Thank you for using this product. This is a specialized electronic product. Incorrect operation may result in damage to the product, personal injury, or even death. The legal consequences resulting from incorrect operation shall be borne by the user. Minors under the age of 18 are not allowed to use this product. To ensure user experience and personal safety, please read the following documents carefully before using this product:

K03 User Manual

Item List

This manual is subject to update without prior notice.

Disclaimer

Before using this product, please carefully read and comply with all the safety instructions in this document and those provided by GDU-Tech Co., Ltd., otherwise it may cause harm to you and people around you, and damage to the product and surrounding items. Once you use this product, it will be deemed that you have carefully read, understood, agreed to, and accepted all the terms and contents of this document and all related documents of this product.

The user agrees to take full responsibility for using this product and any possible consequences. The user undertakes to use this product only for legitimate purposes and agrees to the relevant laws of this agreement.

GDU-TECH is not responsible for any damage, injury or any legal liability caused by the direct or indirect use of this product.

For issues not covered in this statement, please refer to the relevant laws and regulations of the local country. If this statement conflicts with the relevant laws and regulations of the local country, please refer to the laws and regulations of the local country.

GDU-TECH holds the final right of interpretation of this document and all related documents of this product. The content is subject to update without prior notice.

Product Overview

Introduction

The K03 docking station is a fully automated unmanned operation platform featuring automatic charging capabilities and quick mission response. The docking station has a miniaturized and integrated design featuring wide-angle surveillance cameras, an anemometer, a rain gauge, communication antennas, RTK modules, UPS power supplies, etc. The K03 docking station has strong environmental adaptability, with the working environment temperature spanning from -20°C to +50°C, built-in lightning protection function, and a protection level of IP55. Equipped with a fast charging module, it only takes 35 minutes to charge from 10% to 90%. In addition, the built-in air conditioning system can quickly cool down the battery. It has a mission coverage of up to 8km. Weighing approximately 49kg and occupying a space of less than 0.36m², it is easy to install and deploy.

UVER is a UAV mission management platform that supports route planning, flight mission settings, flight information synchronizing, media files uploading and downloading for live viewing, and remote debugging. It can make flight operation management efficient and visualized, realizing unattended operation.

Highlights

1. Lightweight deployment and easy operation and maintenance: K03 weighs approximately 49kg, can enter an elevator, and can be easily handled by two people.
2. Industrial protection, resistant to wind and rain: safe operation in all weathers, resistant to wind and rain erosion, IP55 protection level when closed.
3. Supercharging, quick response: with the S200 Series, aircraft can achieve fast charging, powering up from 10% to 90% battery level in just 35 minutes
4. Compact structure and stable operation: The K03 docking station adopts the gravity centering method rather than the mechanical centering structure to streamline the structure and improve stability.
5. Night operation: supporting precise night landing for non-stop operation.
6. Remote control, easy switching: during the autonomous flight of the drone, the docking station can switch to manual flight mode to control the drone, or Tap-fly, Point of Interest, Touch-fly.
7. Frog-jump flight: supporting drones to operate in a frog-jump manner, effectively increasing the duration and scope of inspection operations.
8. Tower Deployment: The K03 can be installed on the China Tower and power towers, effectively locating suitable deployment sites.
9. Deep standby, ultra-low power consumption: K03 has a deep standby function, reducing standby power consumption to below 10W, and achieving long-time standby under solar power supply.
10. Open interface, empowering the industry: The K03 docking station system supports open APIs, which can be called by developers from various sectors, significantly empowering various industry application scenarios.

Docking Station

Component List

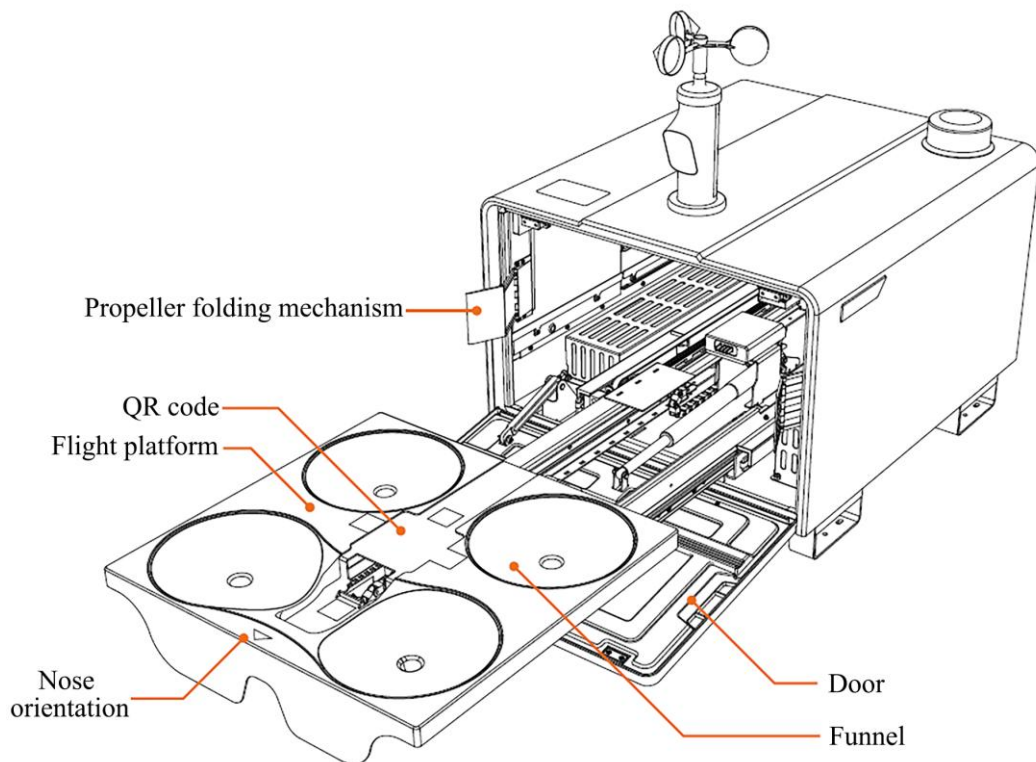
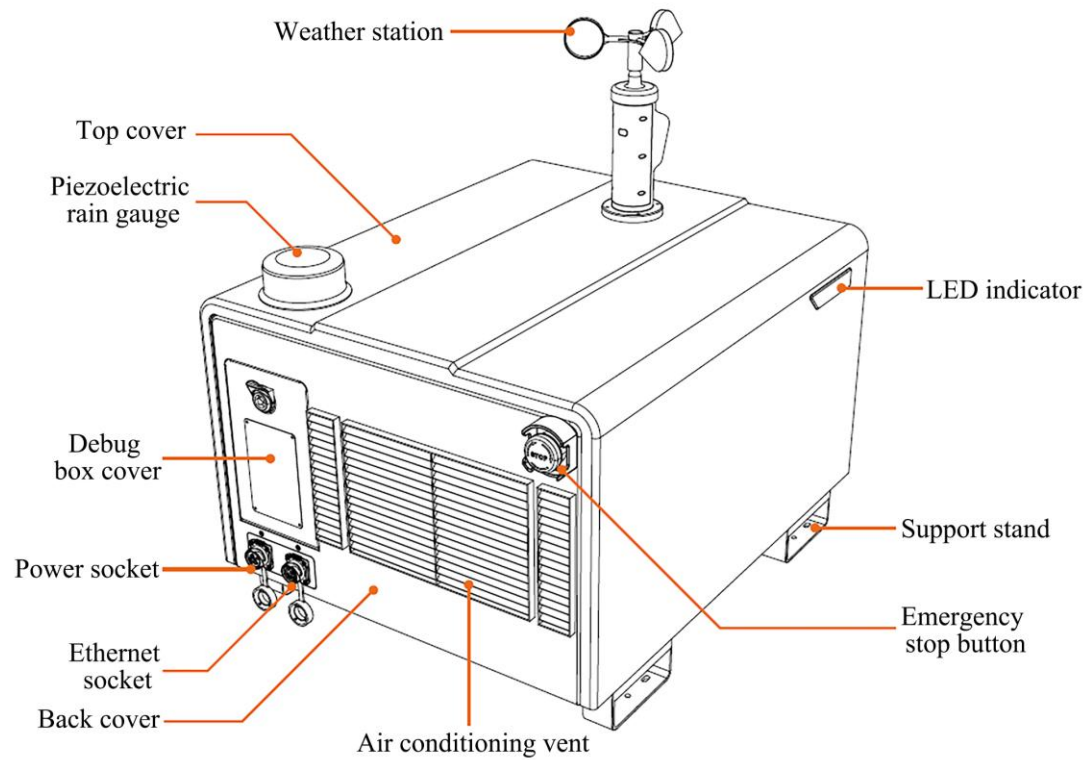

Debug Box

Instructions for Debug box buttons:

Open door: control the opening and closing of the cabin door.

Extend: control the expansion and contraction of the apron.

Force start: use UPS power to forcefully start the docking station.

Power switch: power supply to the docking station.

4G card slot: insert a 4G card to provide 4G network for the device.

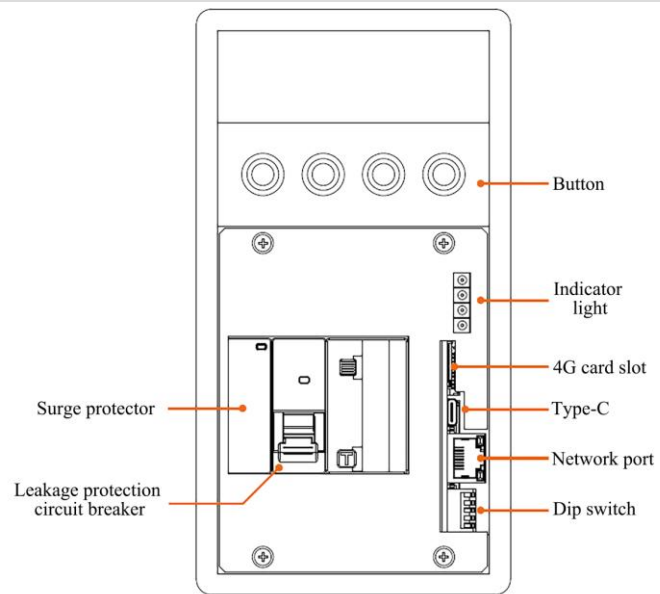

Emergency Stop

The docking station has an emergency stop button. When an emergency occurs during equipment maintenance and debugging, you can press the emergency stop button to stop the movement of the docking station and ensure personal safety. If the aircraft motor is not started, pressing the emergency stop button will prevent the aircraft inside the docking station from performing the flight mission. If the aircraft has taken off, pressing the emergency stop button means that the aircraft will complete the flight operation and then land at the alternate landing point.



- Note: When the emergency stop button is pressed, you need to pull it out or rotate it clockwise to release the emergency stop button before continuing other operations (such as controlling the hatch, etc.).

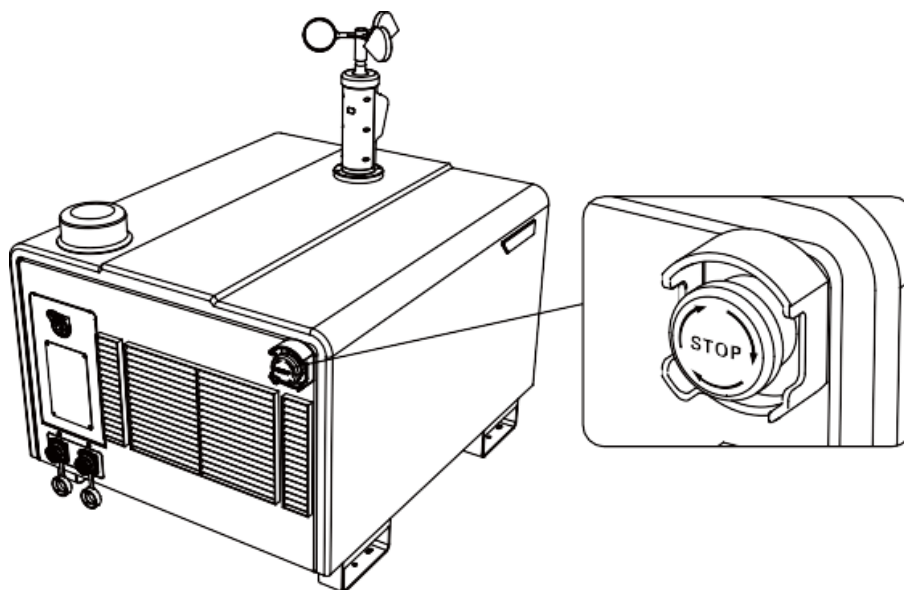

Door

The hatch cover joint has a built-in heating strip, which automatically starts heating at low temperatures to assist in deicing the hatch cover joints.

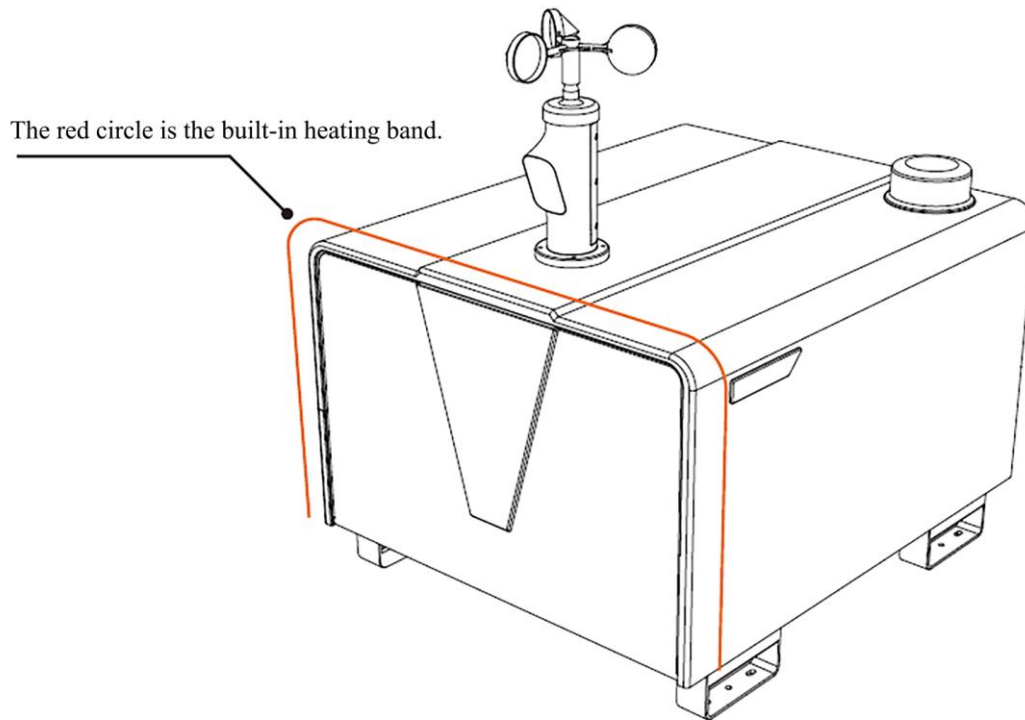

Docking Station LED Indicator

LED indicator	Description
Green light solid on	Docking station in normal status
Red light solid on	Docking station in abnormal status
Red light flashes	Aircraft abnormal alarm
Green light flashing	Aircraft performing a mission
Red, blue and green lights flash alternately	During the takeoff phase, prompt the user to stay away
Blue light flashes	Aircraft battery charging

Docking Station Environment Perception

Monitoring camera and fill light

The docking station is equipped with two surveillance cameras and one fill light.

Surveillance camera: used to monitor the real-time situation of the docking station. Users can view the internal and external environment of the docking station in real time on the UVER interface, which assists operators in remotely observing weather conditions, on-site environment, and aircraft takeoff and landing performance.

Camera fill light: it automatically turns on at night or in low light to assist the aircraft in visual identification.

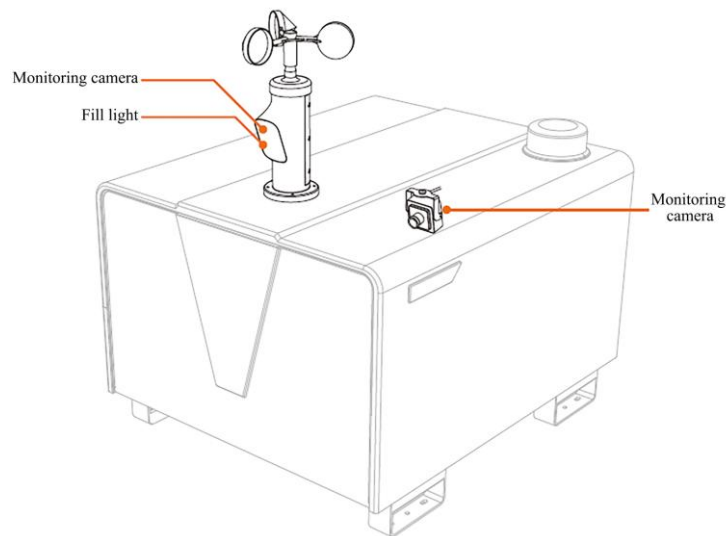

Anemometer

The anemometer is used to monitor the wind speed outside the docking station environment; it has a heating function and can work in low-temperature environments. Users can view real-time wind speed on UVER. To ensure flight safety, flight operations are prohibited when wind speed exceeds the limit.

-
-  • The anemometer can only measure the environmental wind force at the installation location of the docking station, which may differ from the information provided by the local meteorological department. When the aircraft reaches high altitude, the wind speed and direction may undergo sudden changes. Be cautious when flying in strong winds.
-

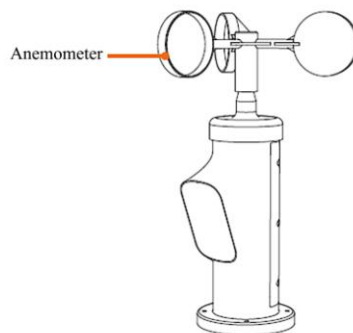

Rain gauge

The rain gauge is used to monitor the rainfall information at the location of the docking station. Users can view rainfall information on the UVER interface. To ensure flight safety, flight operations are prohibited when there is heavy rainfall.



- The rain gauge has a built-in pressure sensor. Please do not heavily hit the surface of the rain gauge to avoid damaging the pressure sensor. The surface of the rain gauge should be regularly cleaned and maintained. If there are dents or deformations, it should be repaired in a timely manner.
- If there is a vibration source near the docking station (such as near a railway), it may cause the rain gauge to falsely report rainfall. When selecting a deployment location, try to avoid strong vibration sources and areas with strong noises.

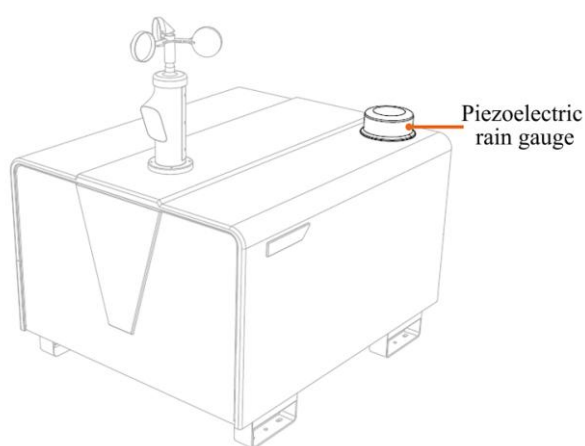

Water immersion sensor

The docking station is equipped with water immersion sensors to detect whether the interior of the docking station is flooded. If the UVER interface displays a water immersion alarm, the docking station will prohibit task execution. In addition, professional personnel need to go to the site and disconnect the power supply of the docking station, clean up the water, and cut off the power supply after checking it is normal. If the docking station malfunctions, disconnect the power supply and contact GDU technical support.

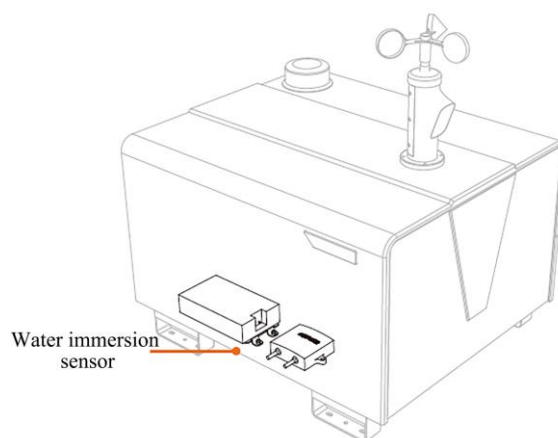

Light sensor

The docking station is equipped with light sensors to detect the lighting conditions outside the docking station. Weak light environment will activate the fill light to assist in precise landing.

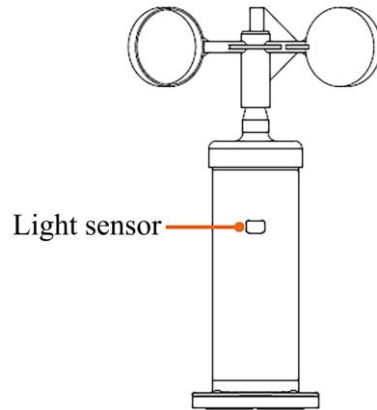

Landing Pad

1. Nose direction mark: When placing the aircraft on the apron, the nose direction must be consistent with the arrow on the apron, otherwise the aircraft will be damaged.
2. Visual identification mark: There is a visual QR code on the apron to help the aircraft identify the docking station location during landing. Please ensure that the identification mark is not blocked or dirty.

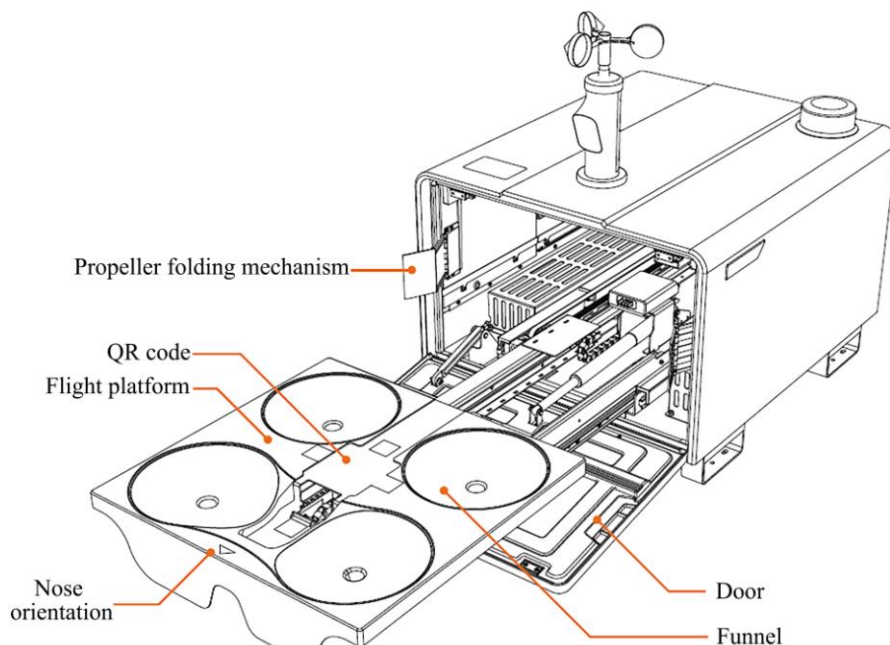

Air Conditioning System

The docking station is equipped with a built-in air conditioning system that can automatically adjust the temperature inside the cabin, providing a suitable storage environment for aircraft and batteries. Users can view and switch on/off the air conditioner on the UVER interface.

Docking Station RTK

The RTK base station for the docking station can achieve centimeter-level positioning accuracy. To ensure accurate flight routes, it is necessary to calibrate the aircraft's RTK in the docking station before executing the flight mission. When installing and configuring the docking station, please calibrate the docking station's RTK parameters through the embedded web page. After successful calibration, as long as the position of the docking station remains unchanged, recalibration is not necessary. If the position of the docking station changes, recalibration is needed.



- During the operation of docking station RTK (such as setting an alternate landing point or the aircraft performing a high-precision RTK mission), do not move, restart, or recalibrate the docking station.
- An active or flickering ionosphere may affect the RTK positioning accuracy. It is not recommended to calibrate the docking station position.

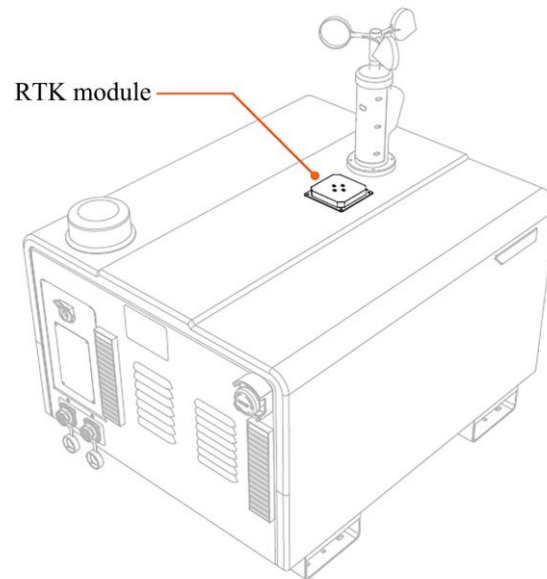

Docking Station Protection Level

1. When used with the S200 series aircraft, the K03 can achieve the P55 protection level under controlled laboratory conditions according to the IEC60529 standard. Protection level is not permanently effective and may decrease due to long-term use. Please perform regular maintenance.
2. The following conditions may compromise the IP55 protection level.
 - The power distribution cabinet door is not closed;
 - The anemometer fixing screws are not tightened;
 - The hatch is not closed;
 - Other possible damage to the fuselage, such as cracked shell.

Instructions for UVER

System Login

Users should use a browser to access the docking station management system, enter the assigned account password and enterprise code, and then enter the verification code to log in.

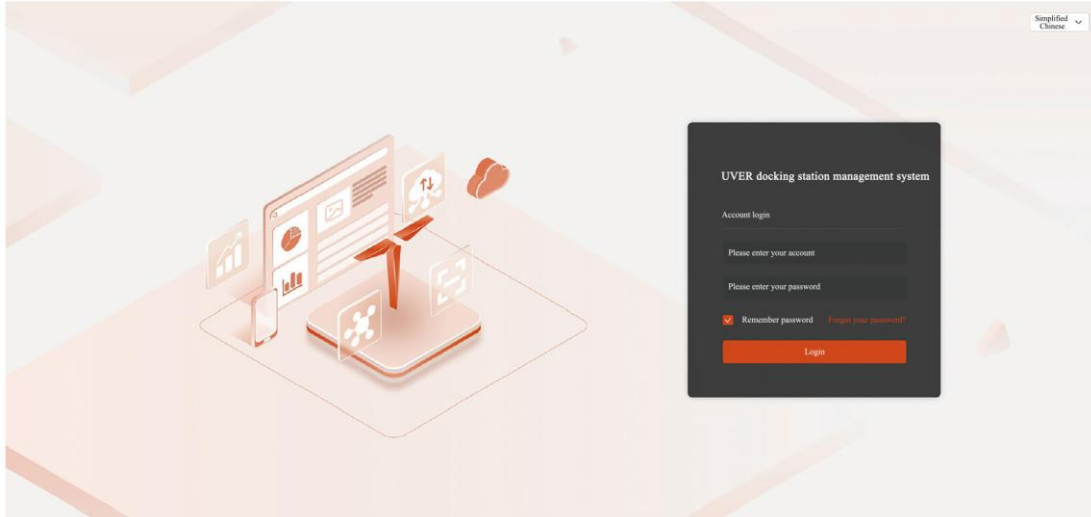

Docking Station Control

The docking station control interface is the homepage of the UAV automatic airport management system. The main functions include docking station viewing and control, aircraft viewing and control, mission execution status and operation, etc.



Docking Station List

Click the "Docking Station List" button to display the docking station list. Users can click on the docking station they want to view and enter the docking station details page to view the docking station operation status, docking station monitoring screen or control the docking station.

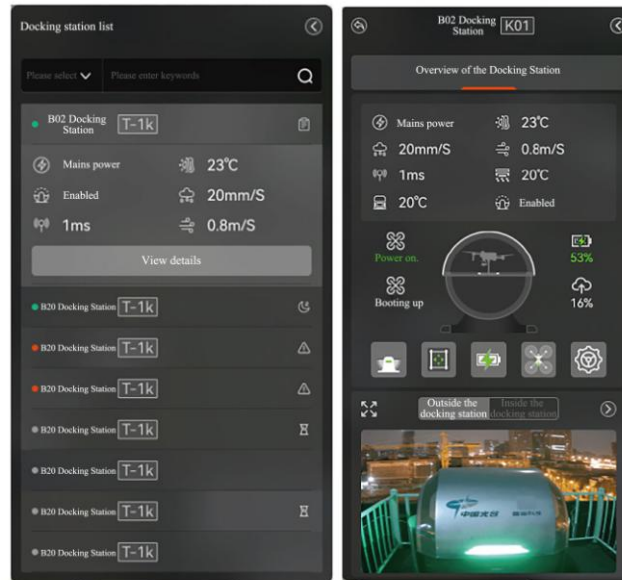

Aircraft List

Click the "Aircraft List" button to display the docking station list. Users can click on the aircraft to view its current operational status, flight parameters, and real-time video of the aircraft.

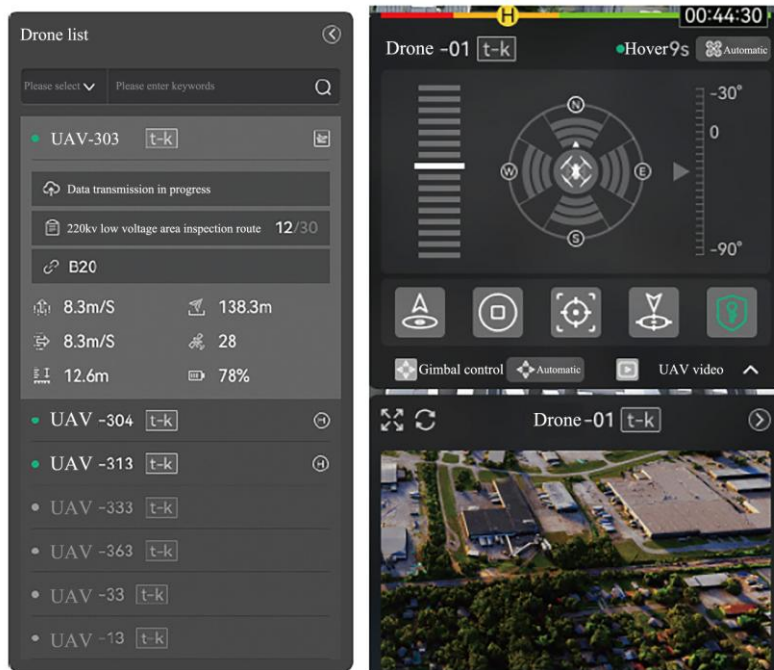

Task List

The task list contains all route tasks. When you want to manually execute a route, execute it via manual task; when you want to check the execution status of a regular task, check it on the regular task page.



Aircraft Control

When a docking station (aircraft connected) or a connected aircraft is selected, the user can control the current aircraft. The platform supports the following functions: one-key takeoff, emergency hover, tap -fly, precise return, control authorization.

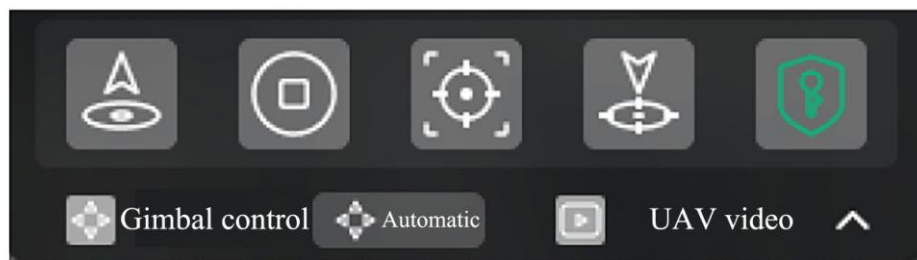

Route Management

The route management module supports functions of planning, managing, storing, importing and exporting routes. The platform provides users with a variety of route types to meet different flight operation scenarios.

Add a new route

Click the “New Route” button to enter the page for adding a new route.

When adding a new route, first draw the route on the map, then configure the route information and waypoint information on the left, and click "OK" to complete.

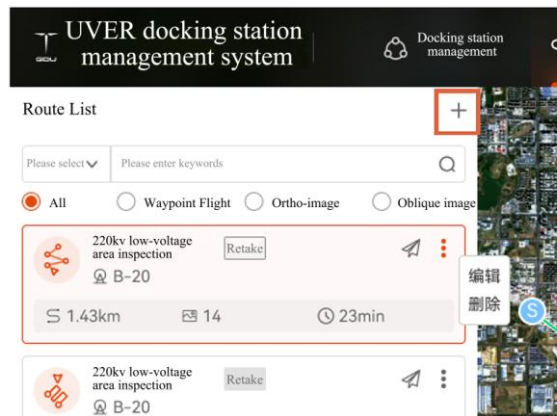

View route

Click the route card to view the route planning and route information on the right map and the information bar below.

Delete route

Click the route card to view the route planning and route information on the right map and the information bar below.

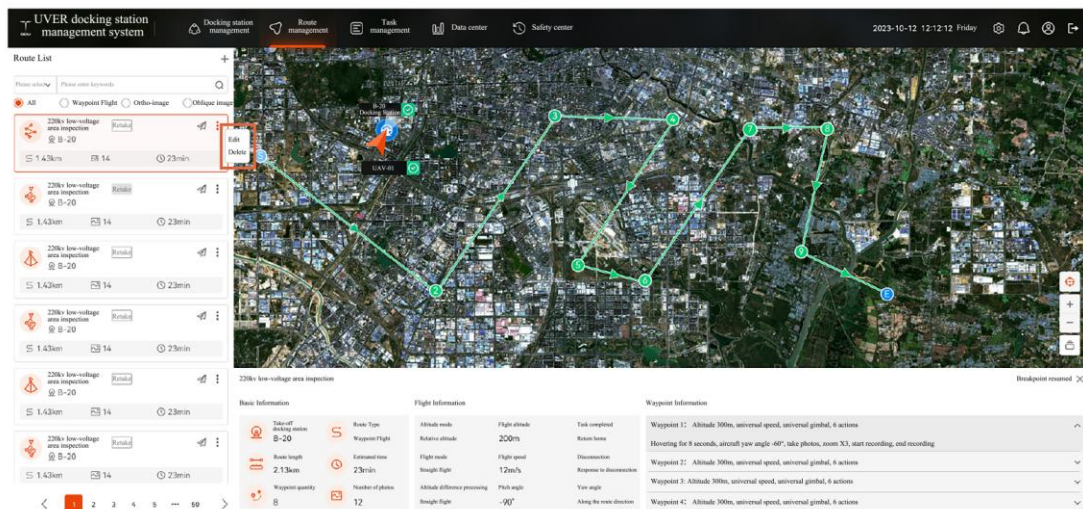

Task Management

Create a new task

1. Click the "Create a new task" button in the task management interface to enter the task planning module.

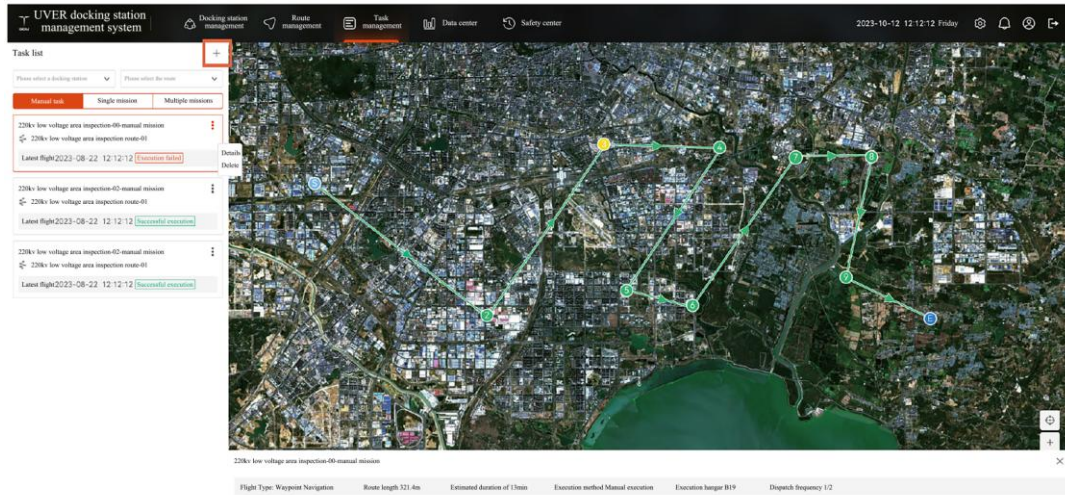

2. On the new task interface, fill in the task name, execution library, execution route, execution method, etc. After filling all the fields, you can select the execution time and add the execution date to the task calendar.

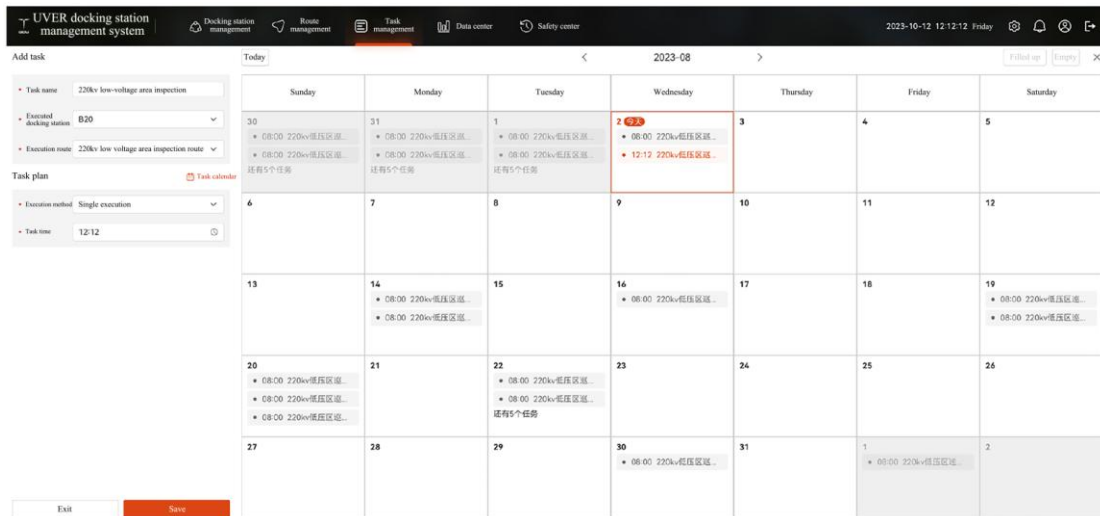

View tasks

The task list supports docking station or route filtering. Click on the task card to display the route and task execution information of the task execution on the map. Click on the task card expansion button, click on details, to view the record of task execution.

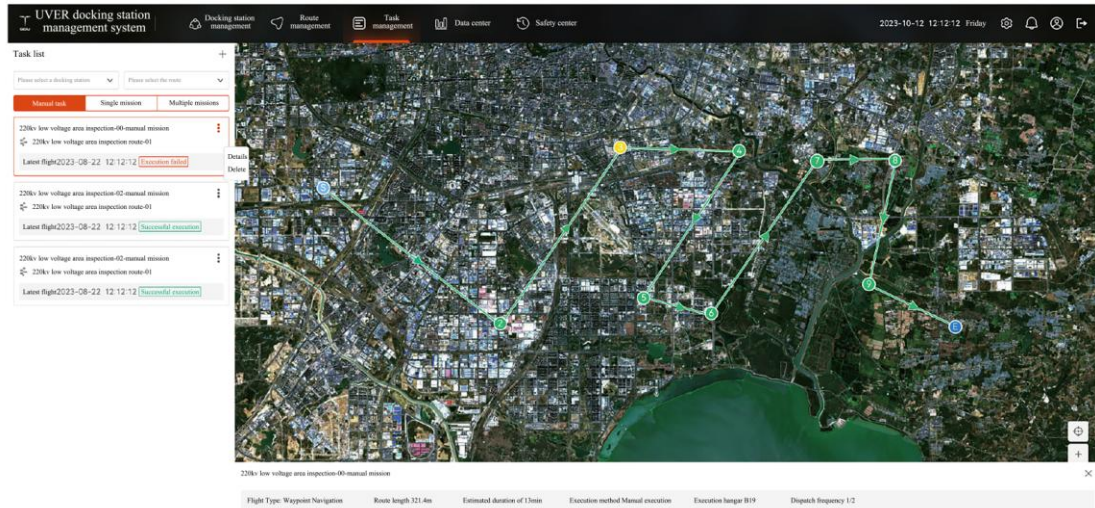

Delete task

The task list supports docking station or route filtering. Click on the task card to display the route and task execution information of the task execution on the map. Click on the task card expansion button, click on details, to view the record of task execution.

Data Center

View task results package

The collection results are packaged according to the mission sorties, and docking stations and routes filtering are supported. Click to enter the sub-menu to view the photos of the mission results package.

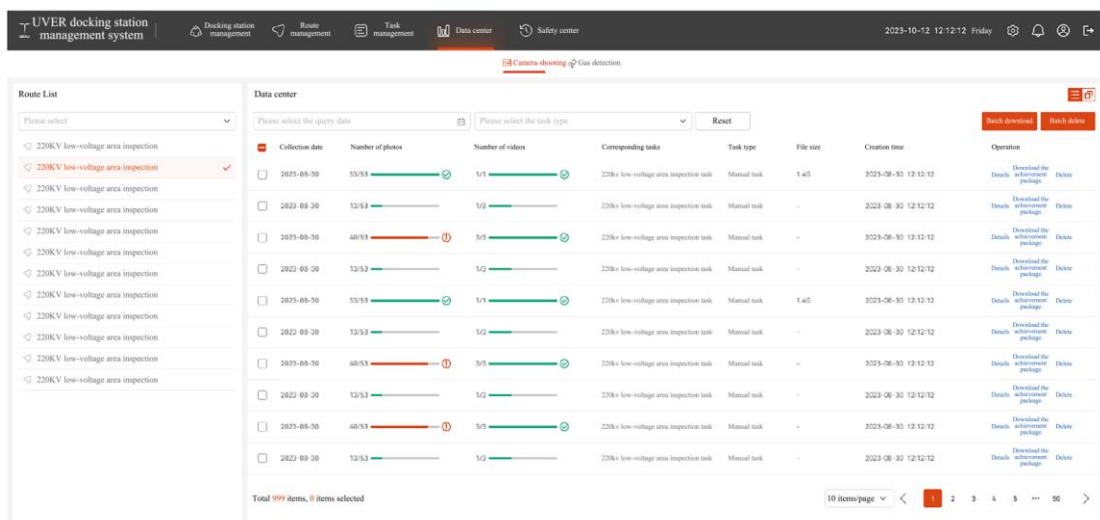

Under the results list, click on the details to view the large picture.



Delete mission results package

Users can click "Delete" in the list or in large image mode.

Appendix

Appearance	
Size	Size of the closed cabin door: 650mm×555mm×370mm. Size of the closed cabin door: 1380mm×555mm×370mm (Excluding the heights of the meteorological stations and tripod)
Weight	49kg ± 1kg
External fill light	Supported
Docking station status indicator	Supported
Operation capability	
Applicable models	S200 series
Mains power supply	100VAC - 240VAC, 50/60HZ
Power consumption	Peak power consumption ≤1000W
Deployment scenario	Ground, roof, tower
Emergency battery	≥ 5h
Charging time	≤35 minutes (charging time at ideal temperature from 10% to 90%)
Precise landing at night	Supported
Frog-jump inspection	Supported
Data storage	Supported
RTK base station	Supported
Maximum inspection range	8,000m
Wind resistance	Inspection phase: Level 6 (12m/s) Landing phase: Level 5 (8m/s)
Edge computing module	Optional
Mesh module	Optional
Industrial protection	
Working environment temperature range	From -20 °C to +50 °C
Maximum working altitude	5,000m
Relative humidity of external environment	<95%, it can work normally
Antifreeze	Supported
Dust and waterproof level	IP55
Lightning protection	Supported
Salt spray protection	Supported
Drainage	Supported

Vibration protection	Supported
Prevent small animals and insects	Supported
Environmental perception	
Outside temperature	Supported
Outside humidity	Supported
Outside rain monitoring	Supported
Outside wind monitoring	Supported
Inside temperature monitoring	Supported
Inside humidity monitoring	Supported
Light sensor	Supported
Smoke monitoring	Supported
Vibration sensor	Supported
Water immersion monitoring	Supported
Unmanned aerial vehicle surveillance	Supported
External camera	Supported
Open interface	
API	Supported
Communication method	
Network port	Support 10/100Mbps adaptive Ethernet port access
4G	Support (SIM card required)

The content is subject to update without prior notice.

**You can check the latest version on the official website of GDU Technology
www.gdu-tech.com**

Copyright © 2024 GDU-Tech Co., Ltd. All rights reserved.

FCC Warning

This device complies with part 15 of the FCC rules. Operation is subject to the following two conditions: (1) this device may not cause harmful interference, and (2) this device must accept any interference received, including interference that may cause undesired operation.

Changes or modifications not expressly approved by the party responsible for compliance could void the user's authority to operate the equipment.

NOTE: This equipment has been tested and found to comply with the limits for a Class B digital device, pursuant to part 15 of the FCC Rules. These limits are designed to provide reasonable protection against harmful interference in a residential installation. This equipment generates uses and can radiate radio frequency energy and, if not installed and used in accordance with the instructions, may cause harmful interference to radio communications. However, there is no guarantee that interference will not occur in a particular installation. If this equipment does cause harmful interference to radio or television reception, which can be determined by turning the equipment off and on, the user is encouraged to try to correct the interference by one or more of the following measures:

-Reorient or relocate the receiving antenna.

- Increase the separation between the equipment and receiver.
- Connect the equipment into an outlet on a circuit different from that to which the receiver is connected.
- Consult the dealer or an experienced radio/TV technician for help.

Radiation Exposure Statement

This equipment complies with FCC radiation exposure limits set forth for an uncontrolled environment. This equipment should be installed and operated with minimum distance 20cm between the radiator and your body.



Scan the WeChat code to follow GDU-Tech Co., Ltd.

Professional Installation Attestation Letter

Date: November 30, 2024

FCC ID: 2A8WC-K03

Model Number: GDU-K03

To: Federal Communication Commission
Authorization and Evaluation Division 7435 Oakland Mills Road
Columbia, MD 21048

To Whom It May Concern,

We, **GDU-Tech Co., Ltd.** hereby declare that our product (**DOCKING STATION**)
Model Number: **GDU-K03** hereby declares that requirements of KDB 353082 D01
Antennas Part 15 Transmitters v01 have been met and shown on the following questions.
Further we declare that the information listed below are correct and represent the
product in consideration under this filing.

1. Professional installation must be justified in the filing, and grant condition must state
"This device must be professionally installed."

**Description: Device is DOCKING STATION and must need special trained
professional in configurating and installing the product. More details please refer to
user manual exhibits.**

2. Professional installation does not permit use of any antenna with the transmitter;
the permitted types of antenna must be specified.

**Description: Device use internal FPC antenna and meet FCC Part 15.203 antenna
requirements.**

3. The applicant should address the following items when justifying professional
installation.

- i) To qualify for professional installation, the applicant must explain why the
hardware

**Description: Due to this product will not be sold directly to the general public
through retail store therefore the hardware is not readily available to average
customer.**

- ii) Marketing – Device cannot be sold via retail to the general public or by mail
order; it must be sold to authorized dealers or installers only

**Description: Due to this product will not be sold directly to the general public
through retail store. It will be sold to authorized declarers or install only.**

- iii) Filing must show that intended use is not for consumers and general public;
rather device is generally for industrial/commercial use.

Description: Device is for industrial/commercial use.

GDU-Tech Co., Ltd.

Building 2, No.5, Huanglongshan South Road, Donghu New Technology
Development Zone, Wuhan 430074, Chin

- iv) Explain what is unique, sophisticated, complex, or specialized about the equipment that REQUIRES it to be installed by a professional installer?
Description: Please be advised that due to the unique Market and function targeted by this product. this product will need special trained professional in selecting the proper location, adjusting the antenna anele on the outside pole or on the wall to satisfy the relevant rule requirements, We hereby declare that the product will be distributed through controlled distribution channel which has special trained professional to install this product and will not be sold directly to the general public through retail store.
4. Other professional installation requirements
- (1) Installation must be controlled.
Description: The product will be distributed through controlled distribution channel which has special trained professional to install this product.
- (2) Installed by licensed professionals (*e.g.*, device sold to dealer who hire installers).
Description: Device sold to dealer who hires installers and need special trained professional in configuring and installing the product.
- (3) Installation requires special training (*e.g.*, special programming, access to keypad, field strength measurements made).
Description: The product needs special programming. access to keypad. field strength measurements made, so must need special trained professional in configuring and installing the product.

Should you have any questions or comments regarding this matter, please have my best attention.

Sincerely,

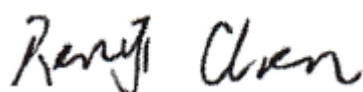

(Signed)

Name / Title: Renyi Chen / Manager

Company: GDU-Tech Co., Ltd.

Address: Building 2, No.5, Huanglongshan South Road, Donghu New Technology
Development Zone, Wuhan 430074, China

Phone: +86-18379713590

Fax: +86-27-81298796

E-Mail: chenrenyi@gdu-tech.com