

Operating instructions
Radar area sensor with CAN
R2Dx

GB

11426718 / 01 07 / 2024



Contents

1	Preliminary note	3
1.1	Symbols used	3
1.2	Warnings	3
1.3	Safety symbols on the unit	3
1.4	Open source information	3
2	Safety instructions	5
2.1	Safety note on high-frequency electromagnetic radiation	5
2.2	Cyber security	6
3	Intended use	7
3.1	Application area	7
3.2	Restrictions of the application area	8
3.3	Impermissible use	9
4	Getting started	10
5	Function	11
5.1	Measuring principle	11
5.2	Operating modes	11
5.3	Overview	12
5.3.1	R2D101	12
5.3.2	R2D103	12
5.3.3	R2D201	12
5.3.4	R2D203	13
5.3.5	R2D205	13
5.4	CAN	13
6	Mounting	14
6.1	Mounting instruction	14
6.2	Mechanical design	15
6.3	Mounting with clamp	15
6.4	Mounting with mounting bracket	16
7	Electrical connection	18
8	Installation	19
9	Operating and display elements	20
9.1	LED states	20
10	Set-up	21
11	Parameter setting	22
11.1	Setting in distance mode	23
11.2	Setting in area mode	24
11.3	Selection rules	25
12	Troubleshooting	26
13	Maintenance, repair and disposal	27
14	Approvals / standards	28
15	Factory setting	29
	Glossary	30

1 Preliminary note

You will find instructions, technical data, approvals and further information using the QR code on the unit / packaging or at documentation.ifm.com.

1.1 Symbols used

- ✓ Requirement
- ▶ Instructions
- ▷ Reaction, result
- [...] Designation of keys, buttons or indications
- Cross-reference
-  Important note
Non-compliance may result in malfunction or interference.
-  Information
Supplementary note

1.2 Warnings

Warnings indicate the possibility of personal injury and damage to property. This enables safe product handling. Warnings are graded as follows:



WARNING

Warning of serious personal injury

▷ If the warning is not observed, fatal and serious injuries are possible.



CAUTION

Warning of minor to moderate personal injury

▷ If the warning is not observed, minor to moderate injuries are possible.

ATTENTION

Warning of damage to property

▷ If the warning is not observed, damage to property is possible.

1.3 Safety symbols on the unit



- Electric supply must correspond to IEC 61010-1, chapter 9.4 - Limited-energy circuit.



- Device of protection class III. Only for operation in SELV/PELV circuits.

1.4 Open source information

This product can contain Free Software or Open Source Software from various software developers which is subject to the following licenses: General Public License version 1, version 2 and version 3 (General Public License version 3 in conjunction with the GNU Compiler Collection Runtime Library Exception version 3.1), Lesser General Public License version 2.1, Lesser General Public License

version 3, Berkeley Software Distribution (BSD-2-Clause, BSD-3-Clause, BSD-4-Clause), MIT-License (MIT), Python Software Foundation License 2.0, Pearl Artistic License and Artistic License 2.0, Microsoft Public License, Apache Software License Version 1.0, 1.1 und 2.0, ISC License, libpng License, zlib License, the Academic Free License version 2.1, Mozilla Public License 2.0.

For the components subject to the General Public License in their respective versions the following applies:

This program is free software: you can redistribute it and/or modify it under the terms of the GNU General Public License as published by the Free Software Foundation. If version 1 applies to the software: either version 1 of the License or (at your option) any later version; if version 2 (or 2.1) applies to the software: either version 2 (or 2.1) of the License or (at your option) any later version; if version 3 applies to the software: either version 3 of the License or (at your option) any later version. The following disclaimer of the software developers applies to the software components that are subject to the General Public License or the implied warranty of MERCHANTABILITY or FITNESS FOR A PARTICULAR PURPOSE. See the GNU General Public License and the GNU Lesser General Public License for more details.

The responsibility of ifm electronic gmbh for ifm products, in the case of product-specific software, remains unaffected by the above disclaimer. Please note that the firmware for the ifm products is in some cases provided free of charge. The price of the ifm products has then to be paid for the respective device itself (hardware) and not for the firmware. For the latest information on the license agreement for your product please visit www.ifm.com

For binaries that are licensed under any version of the GNU General Public License (GPL) or the GNU LGPL or Mozilla Public License 2.0 you may obtain the complete corresponding source code of the GPL software from us by sending a written request to: opensource@ifm.com or to ifm electronic gmbh, Friedrichstraße 1, 45128 Essen, Germany.

We charge €30 for each request. Please write "source for product Y" in the memo line of your payment. Your request should include (i) the name of the covered binary, (ii) the name and the version number of the ifm product, (iii) your name and (iv) your return address.

The following applies to components covered by the General Public License in their respective versions. This offer is valid to anyone in receipt of this information. This offer is valid for at least three years (from the date you received the GPL/LGPL covered code).



For more open source information see: documentation.ifm.com.

2 Safety instructions

- The unit described is a subcomponent for integration into a system.
 - The system architect is responsible for the safety of the system.
 - The system architect undertakes to perform a risk assessment and to create documentation in accordance with legal and normative requirements to be provided to the operator and user of the system. This documentation must contain all necessary information and safety instructions for the operator, the user and, if applicable, for any service personnel authorised by the architect of the system.
- Read this document before setting up the product and keep it during the entire service life.
- The product must be suitable for the corresponding applications and environmental conditions without any restrictions.
- Only use the product for its intended purpose (→ Intended use).
- If the operating instructions or the technical data are not adhered to, personal injury and/or damage to property may occur.
- The manufacturer assumes no liability or warranty for any consequences caused by tampering with the product or incorrect use by the operator.
- Installation, electrical connection, set-up, operation and maintenance of the product must be carried out by qualified personnel authorised by the machine operator.
- Protect units and cables against damage.
- Store the product in its original packaging.

2.1 Safety note on high-frequency electromagnetic radiation

Under application-specific conditions, the risk for the user may differ depending on the installation situation and the device settings.

The system architect/operator is required to carry out a hazard analysis and to take appropriate measures for the protection of persons. In particular national regulations also have to be adhered to. Possible protective measures may include guaranteed minimum distances of a user, access controls and user training.



WARNING

Operation of this device can cause radio interference in residential areas.

- ▷ The device emits high-frequency electromagnetic waves that may interfere with the operation of electronic devices in the vicinity, including pacemakers, hearing aids and defibrillators.
- ▶ Due to human exposure regulations, a minimum distance of 20 cm must be maintained between the device and persons.
- ▶ If you have a pacemaker or other implanted medical product, do not use the device without first consulting your doctor or the manufacturer of your medical product. Keep a safe distance between the device and your medical devices and refrain from further use of the device if you observe permanent impairment of your medical product.

2.2 Cyber security

ATTENTION

Unprotected network environment.

The device does not include IT security measures according to IEC 62443.

- ▷ Unauthorised read or write access to data is possible.
 - ▷ Unauthorised manipulation of the device function is possible.
 - ▶ Check and restrict access options to the device.
-

3 Intended use

3.1 Application area

Based on FMCW radar, the device monitors an area without contact and detects the distance, position and velocity of stationary and moving objects. Target areas, switching limits and zones (ROI) can be defined.

The sensor was designed for industrial use (permanently installed device). However, it can also be used and operated in mobile mode (sensor moves) if the corresponding requirements are met.

The dimension of the detection range of the device depends on the target object to be detected. The detection ranges for defined targets (corner reflectors) are defined in the technical data sheet of the device.

The setting of the device as well as the visualisation of the detection range can be done via the Vision Assistant or moneo.



The application area of the device depends on the base frequency used and the country in which it is operated. Applicable national approval restrictions must be checked prior to set-up of the device. Country-specific features must be taken into account when operating the device.

Operation of the device is only permitted in the countries listed in the package insert "Radio approval". When operating the device in countries that are not on the list, interference with protected frequency ranges may occur.

For USA, Canada, Brazil, Chile:

Devices operating at a base frequency of 60 GHz are intended for static, immobile applications only. The device may move within a fixed installation. This includes stationary applications for collision avoidance, level measurement, object detection, flow measurement and area monitoring. The devices are not approved for **vehicular use**. The following devices belong to this group:

- R2D103

Devices operating at a base frequency of 77 GHz are intended for **vehicular use**. Besides, the devices can be used for fixed and mobile applications in airports in the USA and Canada. The following devices belong to this group:

- R2D201

For Europe, Namibia, South Africa:

Devices operating at a base frequency of 60 GHz can be used for fixed, mobile or portable applications, regardless of the specific application. The following devices belong to this group:

- R2D101

Devices operating at a base frequency of 77 GHz are intended for fixed and mobile transport and traffic telematics (TTT) applications only. This includes, for example, obstacle detection, monitoring of tunnels and level crossings and parking assistance. The following devices belong to this group:

- R2D201

For Australia, New Zealand:

Devices operating at a base frequency of 60 GHz or 77 GHz can be used for fixed, mobile or portable applications, regardless of the specific application. The following devices belong to this group:

- R2D101 / R2D201

For Argentina:

Devices operating at a base frequency of 60 GHz can be used for fixed, mobile or portable applications, regardless of the specific application. The following devices belong to this group:

- R2D101

Devices operating at a base frequency of 76 GHz are intended for **vehicular use**.

The following devices belong to this group:

- R2D205

For India:

Devices operating at a base frequency of 76 GHz can be used for fixed, mobile or portable applications, regardless of the specific application. The following devices belong to this group:

- R2D205

For Japan:

Devices operating at a base frequency of 77 GHz can be used for fixed, mobile or portable applications, regardless of the specific application. The following devices belong to this group:

- R2D203

For Mexico:

Devices operating at a base frequency of 60 GHz can be used for fixed, mobile or portable applications, regardless of the specific application. The following devices belong to this group:

- R2D101

Devices operating at a base frequency of 77 GHz are intended for fixed and mobile transport and traffic telematics (TTT) applications only. This includes, for example, obstacle detection, monitoring of tunnels and level crossings and parking assistance. The following devices belong to this group:

- R2D201

- The device may only be operated in countries for which it has been approved.
- If the device is passed on, the recipient must be informed of applicable national approval restrictions.

The device safety is rated for use under the following operating conditions according to EN IEC 61010-1:2020+A11:2020:

- Protection class 3 (SELV/PELV) and supply of the device to limited energy according to chapter 9.4 IEC 61010-1. The external circuits have to be isolated as required by figure 102 in IEC 61010-2-201.
- Indoor and outdoor use (outdoor use not for cRUus)
- Altitudes up to 2000 m
- Relative air humidity up to max. 90 %, non condensing
- Pollution degree 2

Electromagnetic compatibility (EMC):

The device is designed for use in industrial environments and mobile machines.

- This product may cause radio interference in domestic areas.
- If required, take appropriate EMC screening measures.



The device must be installed in such a way that it cannot be touched by unauthorised persons.

3.2 Restrictions of the application area

The device emits high-frequency electromagnetic waves that are reflected by objects and received and evaluated by the device. The quality of the received energy depends on various object-specific parameters (RCS). Large objects made of metal, for example, are characterised by a high RCS value and can be detected very well by the radar sensor. Objects made of plastics have a small RCS value and cannot always be reliably detected.

Objects with a high RCS value (metals, stone walls) can negatively influence the measurement result and eliminate target objects with a lower RCS value or create false targets.

3.3 Impermissible use

Use that goes beyond the intended use of the device and is outside the technical specification (see data sheet) is not permitted.

The device does not comply with the applicable safety standards for machinery and is therefore not approved as a safety component.

- ▶ Do not use the device in hazardous areas.
- ▶ Only use the operating and adjusting devices (accessories) indicated in the operating instructions.



WARNING

The device does not have self-monitoring redundant circuits and is therefore not intended for operator protection applications. In the event of a defect or device failure, unpredictable switching behaviour of the output may occur.

- ▷ Death or serious irreversible injuries may result.
- ▶ Do not use this device for operator protection.



WARNING

Any impermissible use can lead to dangerous situations.

- ▷ Death or serious irreversible injuries may result.
- ▶ Use the device only in accordance with the "Intended use".
- ▶ Comply with the indications in the operating instructions.
- ▶ Immediately remove damaged products from service.

4 Getting started

For fast set-up, carry out the following steps:

1. Install the device so that it can detect the required area and is not obscured. (→ [Mounting](#) □ 14)
2. Install the CANfox software according to the CANfox operating instructions, as well as the current version of the Vision Assistant.
3. Establish a connection to the device using CANfox.
4. Use the Vision Assistant to make the required settings on the device.



The software is required to configure the device. The software can be downloaded at www.ifm.com.

5 Function

5.1 Measuring principle

The radar sensor determines the distance, position, speed and direction of movement of objects based on FMCW (Frequency Modulated Continuous Wave) radar.

The device emits high-frequency electromagnetic waves which are reflected by the object. The reflected energy is picked up and evaluated by the device's receiving antenna.

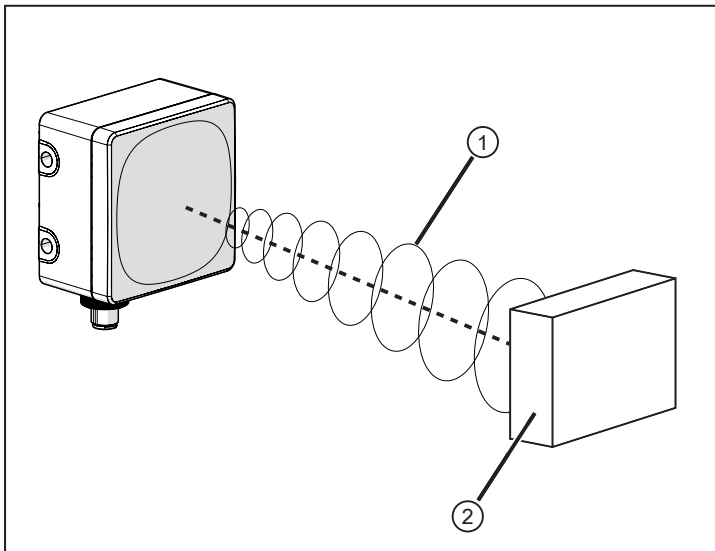

Fig. 1: Measuring principle

1: Radar lobe

2: Object

5.2 Operating modes



The device can only be configured via CAN interface. The software can be downloaded at www.ifm.com.

Depending on the device, up to two different operating modes can be set. These differ in the maximum distance, distance resolution, maximum velocity and velocity resolution.



Not all devices have the option of changing the operating mode. The operating modes and exact technical data are listed in the technical data sheet for the respective device.



If the velocity limits are exceeded, the counter starts over, i.e. the measured value does not correspond to the actual velocity.

5.3 Overview

5.3.1 R2D101

Art. no.:	R2D101
Type designation:	R2DAAOOKG/US/CAN
Angle of aperture:	$\pm 70^\circ$ horizontal / $\pm 25^\circ$ vertical
Function:	radar distance / area sensor
Operating frequency:	60-64 GHz
Type:	rectangular
Radiated transmitter power (e.i.r.p.) and spectral densities (e.i.r.p.):	→ see data sheet



The angle of aperture was determined with a corner reflector (E23013) at a distance of 5 m.

5.3.2 R2D103

Art. no.:	R2D103
Type designation:	R2DADOOKG/US/CAN
Angle of aperture:	$\pm 70^\circ$ horizontal / $\pm 25^\circ$ vertical
Function:	radar distance / area sensor
Operating frequency:	60-64 GHz
Type:	rectangular
Radiated transmitter power (e.i.r.p.) and spectral densities (e.i.r.p.):	→ see data sheet



The angle of aperture was determined with a corner reflector (E23013) at a distance of 5 m.

5.3.3 R2D201

Art. no.:	R2D201
Type designation:	R2DBAOOKG/US/CAN
Angle of aperture:	$\pm 70^\circ$ horizontal / $\pm 15^\circ$ vertical
Function:	radar distance / area sensor
Operating frequency:	77-81 GHz
Type:	rectangular
Radiated transmitter power (e.i.r.p.) and spectral densities (e.i.r.p.):	→ see data sheet



The angle of aperture was determined with a corner reflector (E23013) at a distance of 5 m.

5.3.4 R2D203

Art. no.:	R2D203
Type designation:	R2DBDOOKG/US/CAN
Angle of aperture:	$\pm 70^\circ$ horizontal / $\pm 15^\circ$ vertical
Function:	radar distance / area sensor
Operating frequency:	77-81 GHz
Type:	rectangular
Radiated transmitter power (e.i.r.p.) and spectral densities (e.i.r.p.):	→ see data sheet



The angle of aperture was determined with a corner reflector (E23013) at a distance of 5 m.

5.3.5 R2D205

Art. no.:	R2D205
Type designation:	R2DBBOOKG/US/CAN
Angle of aperture:	$\pm 70^\circ$ horizontal / $\pm 15^\circ$ vertical
Function:	radar distance / area sensor
Operating frequency:	76-77 GHz
Type:	rectangular
Radiated transmitter power (e.i.r.p.) and spectral densities (e.i.r.p.):	→ see data sheet



The angle of aperture was determined with a corner reflector (E23013) at a distance of 5 m.

5.4 CAN

The sensor features a standardised SAE J1939 interface. Parameter setting, diagnostics and firmware update are made via the CAN interface. All measured values and parameter groups can be accessed via the J1939 protocol. For a detailed description of the SAE J1939 protocol and the parameter settings, refer to the software manual.

6 Mounting

ATTENTION

Radiated electromagnetic field strengths

- ▶ The device emits high-frequency electromagnetic waves. It complies with the country-specific limits for the public and workers.
- ▶ Disconnect the device in the vicinity of medical equipment.

6.1 Mounting instruction

- ▶ Storage at high air humidity: Observe the notes in the technical data sheet.
- ▶ Ensure mechanical decoupling when installing the device to prevent the sensor from vibrating.
- ▶ Avoid installation in heavily polluting areas of the machine.
- ▶ Do not paint the device.
- ▶ Provide strain relief for suitable M12 socket.



More information on radar sensor accessories can be found at www.ifm.com.



If there is a risk of damage to the device, it must be installed in such a way that it can only be accessed for occasional work, such as mechanical adjustments, and cannot be touched by unauthorised persons.



Device performance can be affected if positioned in the immediate vicinity of powerful HF emission sources such as welding transformers.

The mounting accessories described in the following sections are recommended for correct installation.

Large metallic objects in the immediate vicinity of the sensing face of the sensor can have a negative effect on the measured signal.

- ▶ When mounting, ensure that there are no unwanted objects within the sensor's field of view (FOV).
- ▶ Observe the horizontal and vertical angles of aperture of the respective device.
- ▶ Lateral elements must be outside the detection angles.

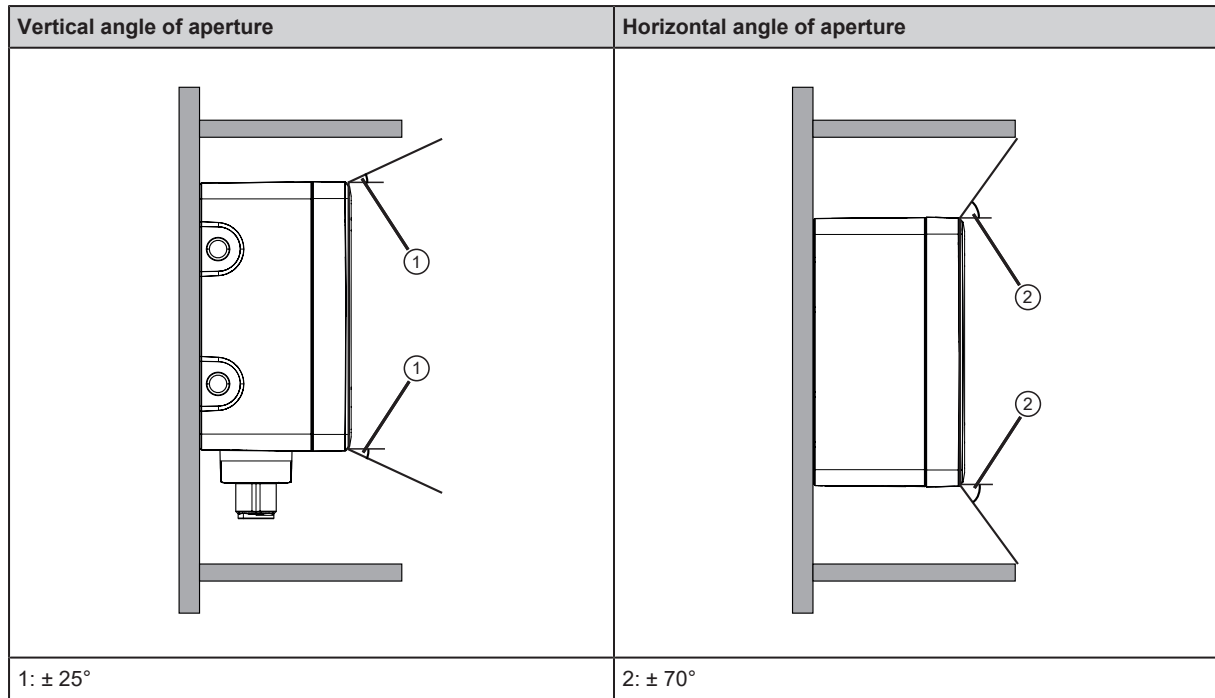

6.2 Mechanical design

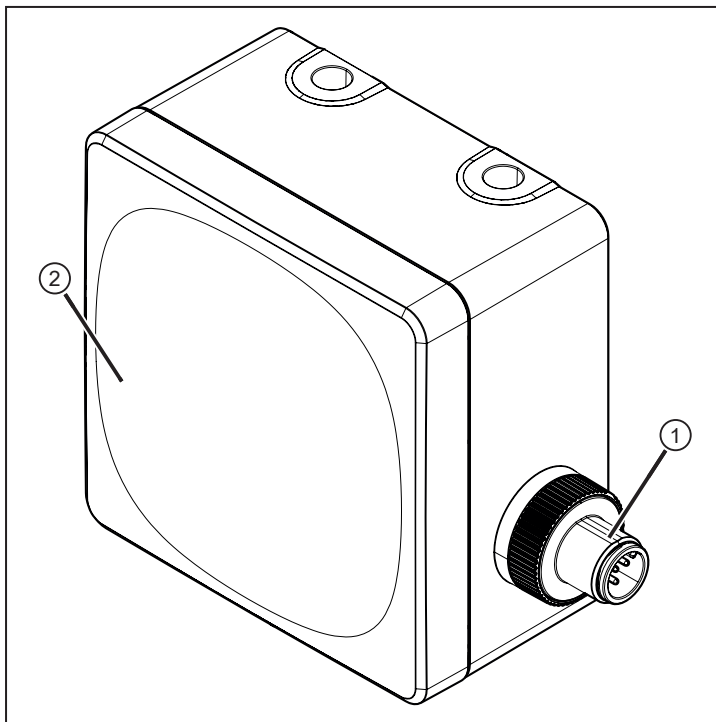

Fig. 2: Mechanical design

1: Connection (can be rotated by 270°)

2: Sensing face

6.3 Mounting with clamp

- ▶ Insert the M5 screws through the through holes of the device and guide them into the threaded M5 holes of the bracket. Tightening torque max. 3.0 Nm.
- ▶ Fix the clamp to the bracket (E23011).

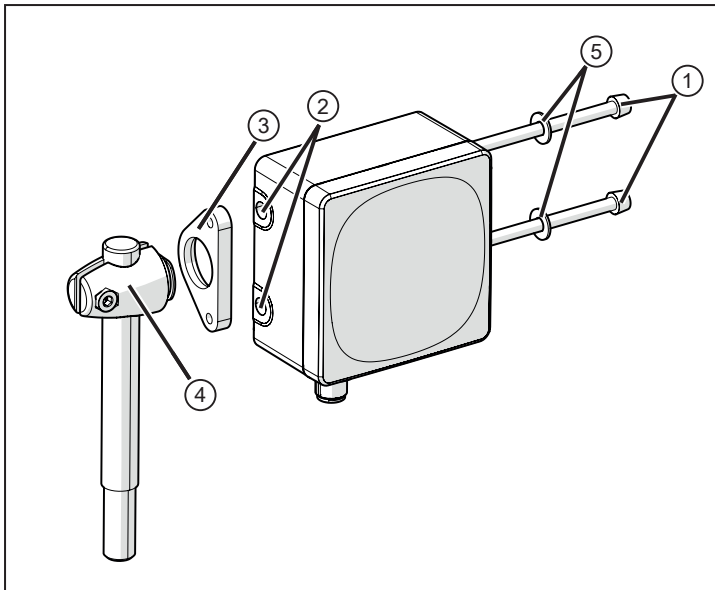

Fig. 3: Mounting

- | | | | |
|----|------------|----|-----------------------------------|
| 1: | M5 screws | 2: | Through holes of the radar sensor |
| 3: | Bracket | 4: | Clamp |
| 5: | M5 washers | | |

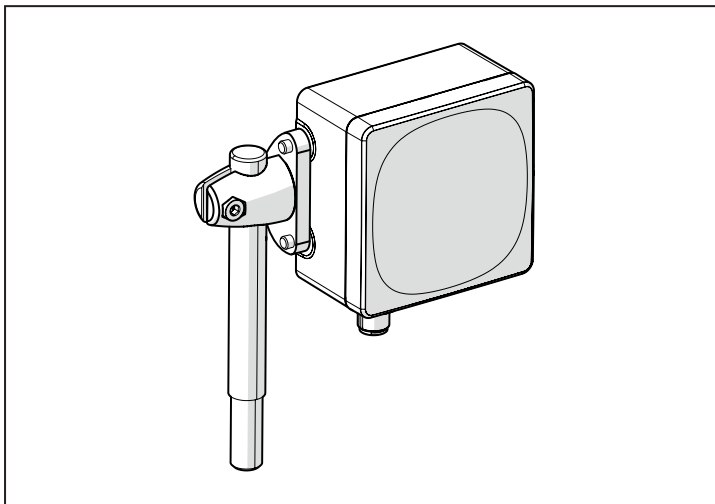

Fig. 4: Completed installation

6.4 Mounting with mounting bracket

By means of the mounting bracket (E23009) the mounting angle of the sensor can be adjusted. A maximum angle of 45° can be set.

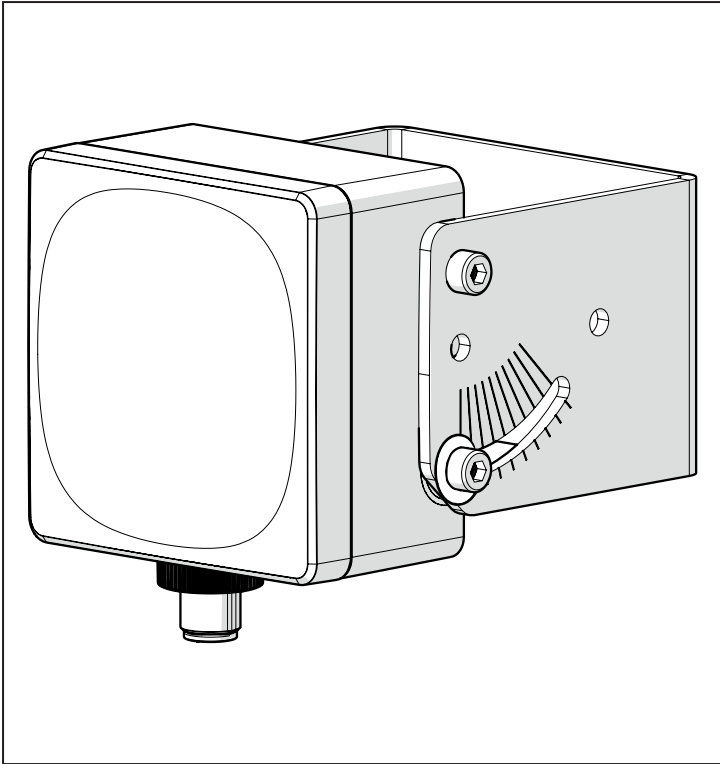

Fig. 5: Example

By means of the mounting bracket (E23010) the mounting angle of the sensor can be adjusted. A maximum angle of 20° can be set.

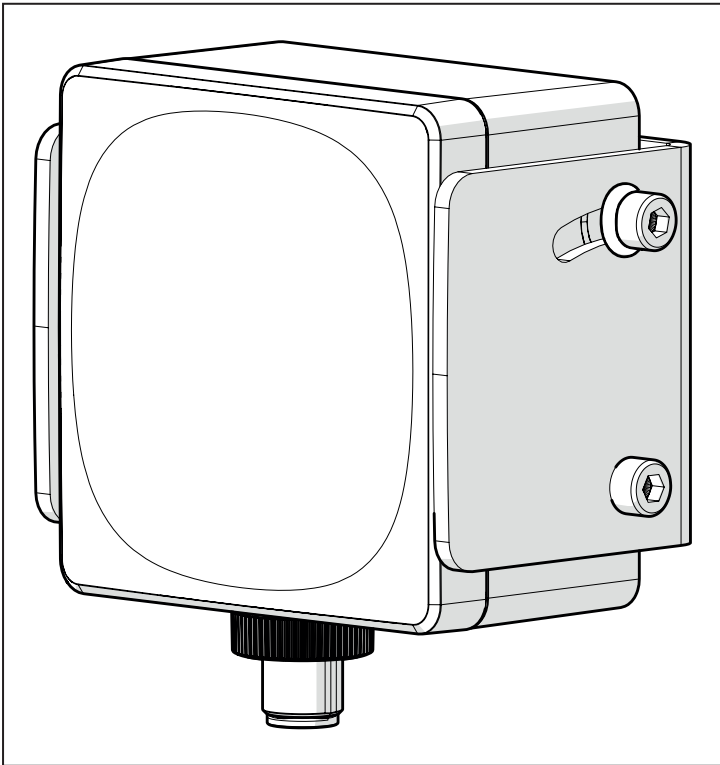

Fig. 6: Example

7 Electrical connection



The unit must be connected by a qualified electrician.

Observe the national and international regulations for the installation of electrical equipment.

Voltage supply according to SELV, PELV.

► Disconnect power.

► Connect the unit as follows:

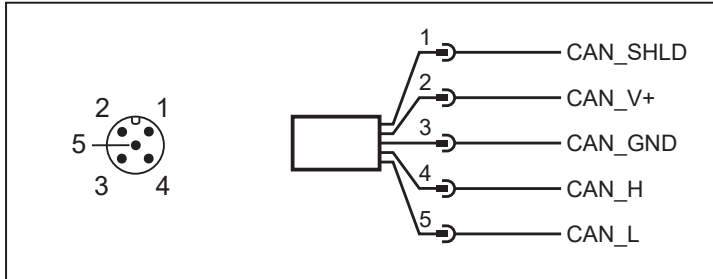

Fig. 7: Wiring diagram

Pin	Assignment	Description
1:	CAN_SHLD	CAN shield
2:	CAN_V+	Supply voltage 24 V DC (+U _B)
3:	CAN_GND	Ground
4:	CAN_H	High bus cable
5:	CAN_L	Low bus cable



Recommendation: Use pre-configured connection cables / sockets, see accessories at www.ifm.com.



The device can be damaged by insufficiently tightened M12 connectors.

The IP rating indicated in the data sheet is only guaranteed if the M12 connectors are firmly screwed.

► Screw the M12 connectors tightly to the device according to the instructions in the corresponding technical data sheet.



For cable lengths longer than 30 m use an additional protection against surge voltages to IEC 61000-4-5.



In the first millisecond after switching on the sensor, the current consumption of the device is increased.

If several radar sensors are connected to one voltage supply, this can lead to the current limitation being activated, especially when restarting after a power failure.

8 Installation

To be able to make full use of the device's functions, the ifm Vision Assistant software is required for parameter setting.

- ▶ Go to the download section at this [link](#) and download the ifm Vision Assistant software onto your computer.



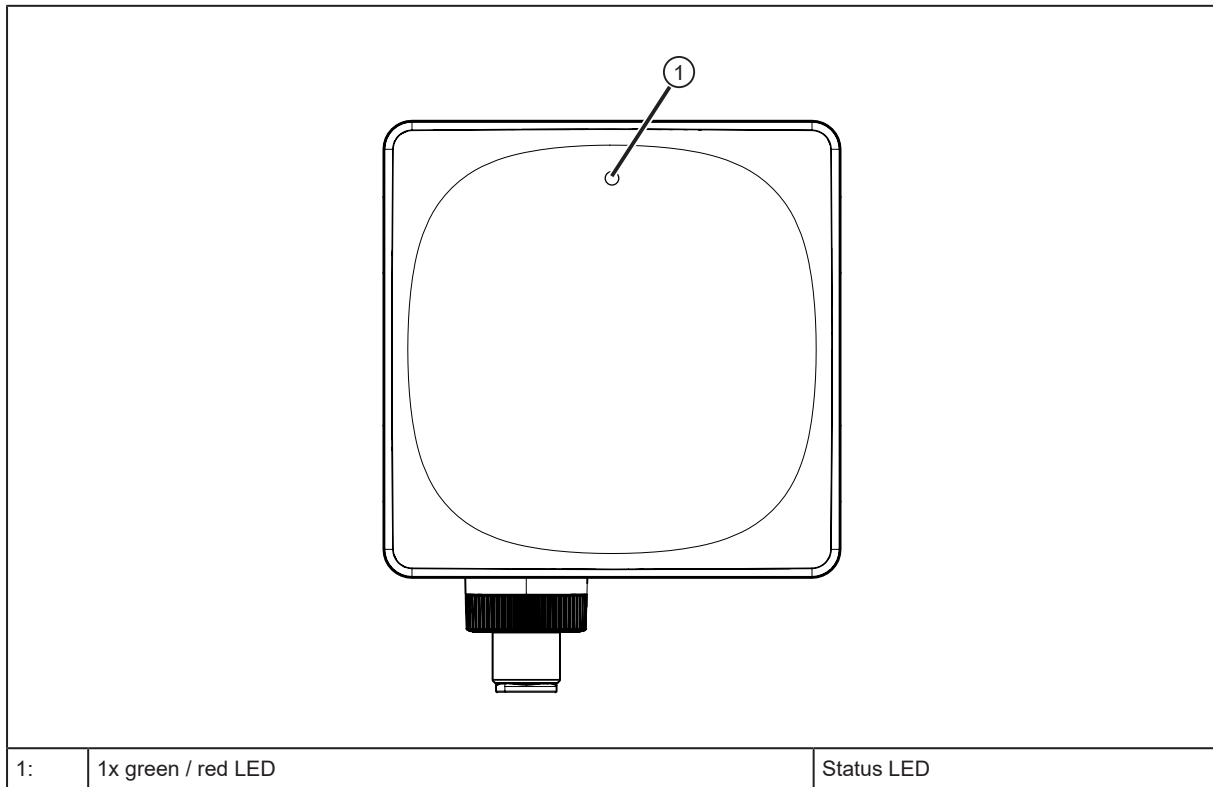

The operation of the ifm Vision Assistant software is described in the software manual. → software manual at www.ifm.com.

9 Operating and display elements



9.1 LED states

LED behaviour	Description	Action
	Status LED is green	Device is connected to the voltage supply and ready for operation
	Status LED flashing red (1 Hz)	Error (correctable by the operator) Troubleshooting
	Status LED is red	Serious error ▶ Contact ifm support. Contact at www.ifm.com

10 Set-up

After power on, the device is put into operation.

After approx. 3 s the device is ready for operation.

On delivery, the parameters are set to the factory setting.

The device is set using the ifm Vision Assistant software.

11 Parameter setting

The device parameters can be set in two ways:

- ifm Vision Assistant software (→ see software manual at www.ifm.com)

The coordinate system

The coordinate system is defined according to the right-hand rule.

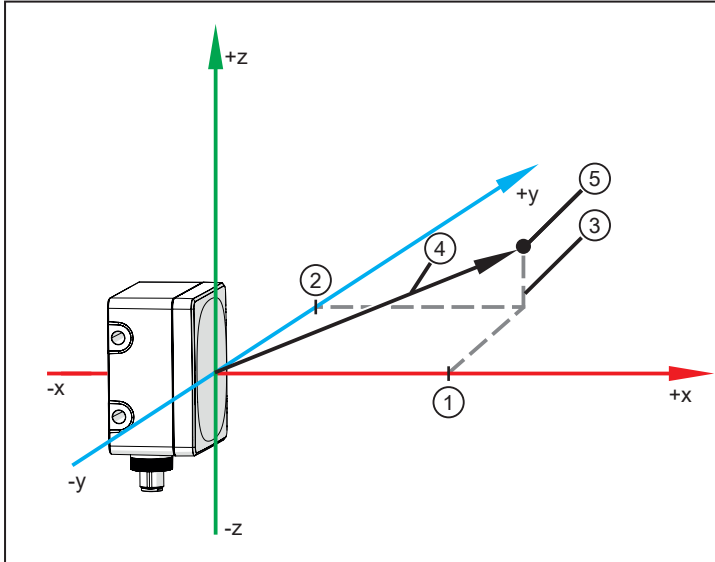

Fig. 8: Schematic illustration in the coordinate system

- | | | | |
|----|---------------|----|------------|
| 1: | X position | 2: | Y position |
| 3: | Z position | 4: | Distance |
| 5: | Target object | | |

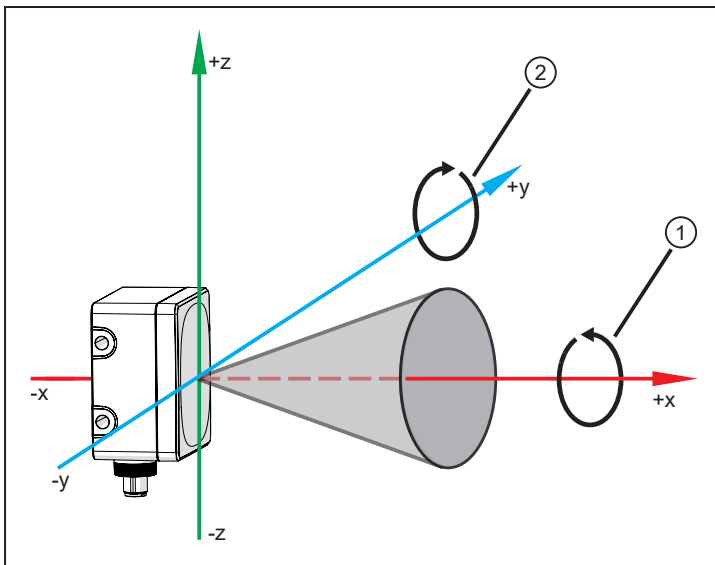

Fig. 9: Schematic illustration in the coordinate system

- | | | | |
|----|--------|----|---------|
| 1: | “Roll” | 2: | “Pitch” |
|----|--------|----|---------|

The following statements apply to vertical mounting of the sensor.

The x coordinate corresponds to the longitudinal distance, with positive sign, pointing away from the centre of the sensing face of the radar sensor at the coordinate origin.

The y coordinate corresponds to the lateral expansion, output with positive signs to the left of the sensor and with negative signs to the right of the sensor, viewed in the positive x direction.

The z coordinate corresponds to the height, output above the sensor with a positive sign and below the sensor with a negative sign.

The device comes with integrated inclination measurement and can output information on its inclination angle. Tilting around the x axis is called “rolling” and tilting around the y axis is called “pitching”.

The velocity of the target object is output with a negative sign when the target object moves towards the sensor.

The velocity of the target object is output with a positive sign when the target object moves away from the sensor.

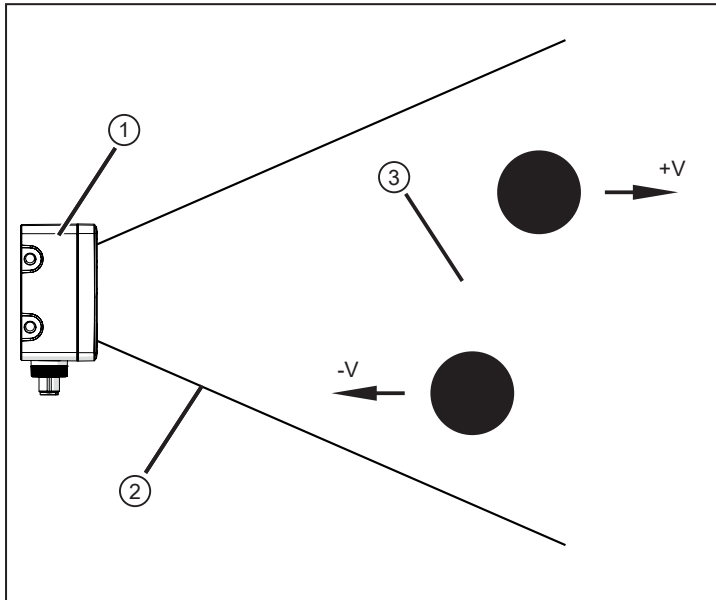

Fig. 10: Schematic illustration of the detection zone

- | | | | |
|----|----------------|----|----------------|
| 1: | Sensor | 2: | Detection zone |
| 3: | Moving objects | | |

11.1 Setting in distance mode

The device has a horizontal angle of aperture of $\pm 70^\circ$. The FOV of the sensor is variable and can be adjusted. The radar sensor is capable of detecting several targets simultaneously.

The maximum range of the device depends on the target object and the selected modulation. As an example, the figure shows the FOV of the device for three objects for the operating mode “Standard”.



For further information → Software manual

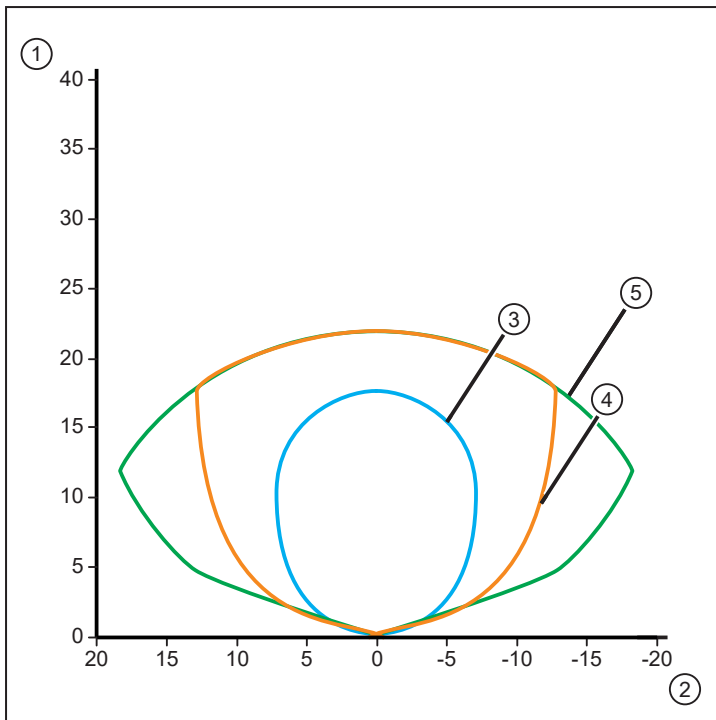

Fig. 11: Top view

- | | | | |
|----|-------------------------------|----|--------------------------------|
| 1: | X axis [m] | 2: | Y axis [m] |
| 3: | Object: pedestrian (-10 dB) | 4: | Object: reflector 50 mm (0 dB) |
| 5: | Object: passenger car (10 dB) | | |

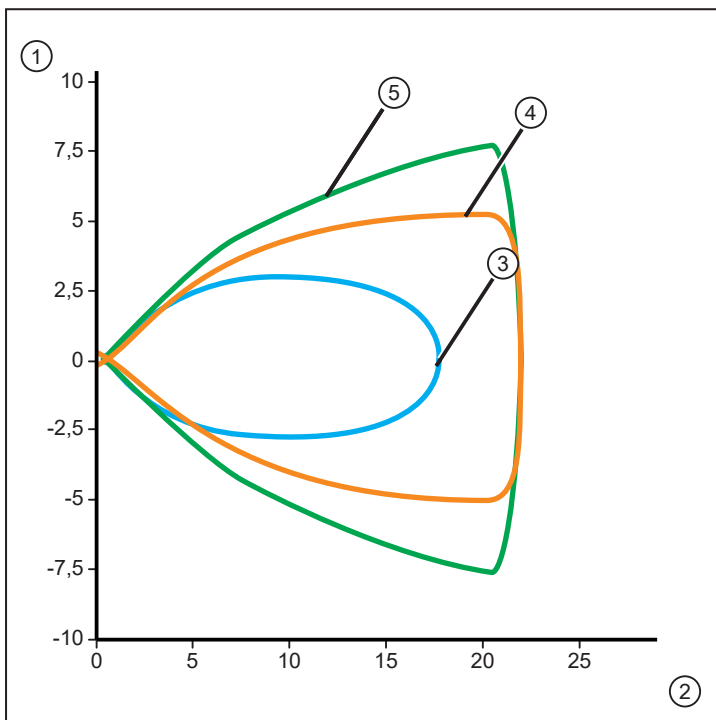

Fig. 12: Side view

- | | | | |
|----|-------------------------------|----|--------------------------------|
| 1: | Z axis [m] | 2: | X axis [m] |
| 3: | Object: pedestrian (-10 dB) | 4: | Object: reflector 50 mm (0 dB) |
| 5: | Object: passenger car (10 dB) | | |

11.2 Setting in area mode

Angle of aperture and range (→ [Setting in distance mode](#) □ 23), setting parameters differ.



For further information → Software manual

11.3 Selection rules

You can choose between the following selection rules:

Selection rule	Description
[Shortest distance]	The target closest to the sensor is selected.
[Strongest power]	The target that has the highest reflected energy is selected.
[Strongest RCS]	The target that has the strongest RCS is selected.
[Highest absolute velocity]	The target that has the highest absolute velocity is selected.
[Longest distance]	The target that is furthest away from the sensor is selected.

12 Troubleshooting

Possible cause	Solution
Ambient temperature too high	▶ Reduce ambient temperature
Supply voltage outside the specification (→ technical data sheet)	▶ Adjust supply voltage

If the device behaves unexpectedly or incorrectly:

- ▶ Download and install the latest firmware and ifm Vision Assistant versions (→ [Installation](#) □ 19). Download at documentation.ifm.com.
- ▶ Disconnect the device from the voltage supply (restart)
- ▶ Reset to factory settings

If the problems persist:

- ▶ Contact the ifm support at www.ifm.com.

13 Maintenance, repair and disposal

If used correctly, the unit is maintenance-free.

- ▶ Keep the sensing face and any clear spaces free from deposits and foreign bodies.
- ▶ It is not possible to repair the unit.

Only the manufacturer is allowed to repair the unit.

- ▶ After use, dispose of the unit in an environmentally friendly way in accordance with the applicable national regulations.

14 Approvals / standards

For approvals and standards, the following information is available:

- Test standards and regulations: documentation.ifm.com
- EU declaration of conformity and approvals: documentation.ifm.com
- Notes relevant for approval: Package insert of the device and documentation.ifm.com
- Impact protection rating IK06 according to IEC 62262.

For the scope of validity cRUus:

The electrical supply must only be made via SELV/PELV circuits. Supply of the device to limited energy according to chapter 9.4 UL 61010-1. The external circuits have to be isolated as required by figure 102 in UL 61010-2-201.

The device safety is rated for use under the following operating conditions:

- Indoor use
- Altitude up to 2000 m
- Maximum relative humidity 90 %, non-condensing
- Pollution degree 2

Use UL-certified cables of category CYJV 2/7/8 with suitable ratings for connecting the device. No special treatment is necessary when cleaning the device.

15 Factory setting

The factory settings of the parameters are available at documentation.ifm.com.

Glossary

RCS

RCS stands for Radar Cross Section (radar signature) and is a measure of how well a target is detectable by radar, i.e. how much of the emitted energy is reflected from a target. The higher the RCS value, the better the reflectivity and thus the visibility of the target. The RCS value depends on factors such as material, size and angle of incidence, but not on the distance of the reflection target, as long as a reflection is not affected by the distance.

Vehicular use

Vehicular use means applications in the vicinity (not inside) a vehicle, where a vehicle is a platform that performs specific tasks to transport someone or something.



Funkzulassung
Radio approval
Agrément radio
Radyo onayı
Aprobación de radio
Aprovação de rádio

R1D1

R2D1



Deutsch

R1D100/R1D101/R2D100/R2D101/R2D110

Vor Inbetriebnahme die Bedienungsanleitung lesen und während der Einsatzdauer aufbewahren.

- Hiermit erklärt die ifm electronic GmbH, dass die oben genannten Geräte der Richtlinie 2014/53/EU entsprechen.
- Der vollständige Text der EU-Konformitätserklärung, Technische Daten, Anleitungen, Zulassungen, Kontakte und weitere Informationen unter documentation.ifm.com.

WARNUNG! Der Betrieb dieses Gerätes kann Funkstörungen in Wohngebieten verursachen.

- Das Gerät hat eine Arbeitsfrequenz von 60 bis 64 GHz und eine mittlere abgestrahlte Leistung von unter 20 dBm e.i.r.p..
- Aufgrund der Human-Exposure-Vorschrift einen Mindestabstand zwischen Gerät und Personen von 20 cm einhalten.
- Das Gerät sendet Funkwellen aus, die möglicherweise den Betrieb von elektronischen Geräten in der Nähe beeinträchtigen, darunter Herzschrittmacher, Hörelemente und Defibrillatoren. Wenn Sie einen Herzschrittmacher oder ein anderes implantiertes Medizinprodukt haben, verwenden Sie das Gerät nicht ohne vorherige Rücksprache mit Ihrem Arzt oder dem Hersteller Ihres Medizinprodukts. Halten Sie einen Sicherheitsabstand zwischen dem Gerät und Ihren Medizinprodukten ein und sehen Sie von der weiteren Verwendung des Gerätes ab, wenn Sie eine dauerhafte Beeinträchtigung Ihres Medizinprodukts beobachten.

English

R1D100/R1D101/R2D100/R2D101/R2D110

Read the operating instructions before set-up and keep them for the duration of use.

- ifm electronic gmbh hereby declares that the above-mentioned devices are in compliance with directive 2014/53/EU.

- The full text of the EU Declaration of Conformity, technical data, instructions, approvals, contacts and further information at documentation.ifm.com.

WARNING! The operation of this device can cause radio interference in residential areas.

- The device has an operating frequency of 60 to 64 GHz and a mean radiated power of below 20 dBm e.i.r.p..
- Due to radio frequency exposure limits this device should be installed and operated with a minimum distance of 20 cm between the device and the body of the user or nearby persons.
- The device emits radio waves that may interfere with the operation of electronic devices in the vicinity, including pacemakers, hearing aids and defibrillators. If you have a pacemaker or other implanted medical device, do not use the sensor without first consulting your doctor or the manufacturer of your medical device. Keep a safe distance between the device and your medical products and refrain from further use of the device if you observe permanent impairment of your medical devices.

Français

R1D100/R1D101/R2D100/R2D101/R2D110

Lire la notice d'utilisation avant l'utilisation et conserver-la pendant toute la durée d'utilisation.

- ifm electronic gmbh déclare par la présente que les appareils mentionnés ci-dessus sont conformes à la directive 2014/53/UE.
- Vous trouverez le texte intégral de la déclaration de conformité de l'UE, les données techniques, les instructions, les homologations, les contacts et d'autres informations sur le site documentation.ifm.com.

AVERTISSEMENT ! Le fonctionnement de cet appareil peut causer des interférences radio dans les zones résidentielles.

- L'appareil a une fréquence de fonctionnement de 60 à 64 GHz et une puissance rayonnée moyenne de moins de 20 dBm e.i.r.p..
- En raison des réglementations relatives à l'exposition humaine, une distance minimale de 20 cm doit être maintenue entre l'appareil et les personnes.

- L'appareil émet des ondes radio qui peuvent interférer avec le fonctionnement des appareils électroniques situés à proximité, notamment les stimulateurs cardiaques, les appareils auditifs et les défibrillateurs. Si vous avez un stimulateur cardiaque ou un autre dispositif médical implanté, n'utilisez pas l'appareil sans avoir consulté au préalable votre médecin ou le fabricant de votre dispositif médical. Maintenez une distance de sécurité entre l'appareil et vos dispositifs médicaux et ne continuez pas à utiliser l'appareil si vous constatez une déficience permanente de votre dispositif médical.

Great Britain

English

R1D100/R1D101/R2D100/R2D101/R2D110

Read the operating instructions before set-up and keep them for the duration of use.

- ifm electronic gmbh hereby declares that the above mentioned devices are in compliance with the relevant statutory requirements.
- The full text of the Declaration of Conformity, technical data, instructions, approvals, contacts and further information at documentation.ifm.com.

WARNING! The operation of this device can cause radio interference in residential areas.

- The device has an operating frequency of 60 to 64 GHz and a mean radiated power of below 20 dBm e.i.r.p..
- Due to radio frequency exposure limits this device should be installed and operated with a minimum distance of 20 cm between the device and the body of the user or nearby persons.
- The device emits radio waves that may interfere with the operation of electronic devices in the vicinity, including pacemakers, hearing aids and defibrillators. If you have a pacemaker or other implanted medical device, do not use the sensor without first consulting your doctor or the manufacturer of your medical device. Keep a safe distance between the device and your medical products and refrain from further use of the device if you observe permanent impairment of your medical devices.

Türkiye

Türkçe

R1D100/R1D101/R2D100/R2D101/R2D110

Kurulumdan önce kullanma talimatlarını okuyunuz ve bunları ürünün tüm kullanım süresince saklayınız.

- ifm electronic gmbh, yukarıda belirtilen cihazların 2014/53/AB sayılı direktifine uygun olduğunu beyan eder.
- Uygunluk Beyanı'nın tam metni, teknik veriler, talimatlar, onaylar, iletişim bilgileri ve daha fazla bilgi burada bulunabilir: documentation.ifm.com.

UYARI! Bu cihazın çalışması, yerleşim alanlarında radyo parazitine neden olabilir.

- Cihaz, 60 ila 64 GHz çalışma frekansına ve 20 dBm e.i.r.p.'nin altında ortalama bir yayılım gücüne sahiptir.
- Radyo frekansına maruz kalma limitleri nedeniyle cihaz, cihaz ile kullanıcının veya yakındaki kişilerin vücudu arasında en az 20 cm mesafe olacak şekilde kurulmalı ve çalıştırılmalıdır.
- Cihaz, kalp pilleri, işitme cihazları ve defibrilatörler (şok cihazı) de dahil olmak üzere çevredeki elektronik cihazların çalışmasını engelleyebilecek yüksek frekanslı elektromanyetik dalgalar yayar. Kalp piliniz veya vücudunuza takılmış başka bir tıbbi ürününüz varsa, cihazı, doktorunuza veya tıbbi ürününüzün üreticisine danışmadan kullanmayın. Cihaz ile tıbbi cihazlarınız arasında güvenli bir mesafe bırakın ve tıbbi ürününüzde kalıcı bir bozulma gözlemlerseniz cihazı daha fazla kullanmaktan kaçının.

USA

English

R1D102/R1D103/R2D102/R2D103/R2D111

FCC information:

This device complies with Part 15 of the FCC Rules. Operation is subject to the following two conditions:

1. This device must not cause harmful interference, and

2. This device must accept any interference received, including interference that may cause undesired operation.

Changes or modifications to this device that have not been expressly approved by ifm could void the user's authority to operate the equipment.

Note:

This equipment has been tested and found to comply with the limits for a Class A digital device, pursuant to part 15 of the FCC Rules. These limits are designed to provide reasonable protection against harmful interference when the equipment is operated in a commercial environment. This equipment generates, uses, and can radiate radio frequency energy and, if not installed and used in accordance with the instruction manual, may cause harmful interference to radio communications. Operation of this equipment in a residential area is likely to cause harmful interference in which case the user will be required to correct the interference at his own expense.

RF Exposure Info:

Due to radio frequency exposure limits this device should be installed and operated with a minimum distance of 20 cm between the device and the body of the user or nearby persons.

The measurement results comply with the FCC limit per 47 CFR §2.1091 for the uncontrolled RF Exposure of mobile devices.

Canada / Canada

English

R1D102/R1D103/R2D102/R2D103/R2D111

ISED note:

This device contains licence-exempt transmitters/receivers that comply with Innovation, Science and Economic Development Canada's licence-exempt RSSs. Operation is subject to the following two conditions:

1. This device may not cause interference.
2. This device must accept any interference, including interference that may cause undesired operation of the device.

This equipment complies with ISED RSS-102 radiation exposure limits set forth for an uncontrolled environment when the device is installed and operated with a minimum separation distance of 20 cm between the device and any human body.

Français

R1D102/R1D103/R2D102/R2D103/R2D111

Avis ISDE:

L'émetteur/récepteur exempt de licence contenu dans le présent appareil est conforme aux CNR d'Innovation, Sciences et Développement économique Canada applicables aux appareils radio exempts de licence.

L'exploitation est autorisée aux deux conditions suivantes:

1. L'appareil ne doit pas produire de brouillage;
2. L'appareil doit accepter tout brouillage radioélectrique subi, même si le brouillage est susceptible d'en compromettre le fonctionnement.

Cet appareil est conforme aux limites d'exposition aux radiations ISDE RSS-102 établies pour un environnement non contrôlé lorsque l'appareil est installé et utilisé avec une distance de séparation minimale de 20 cm entre l'appareil et tout corps humain.

Argentina

Español

R1D100/R1D101/R2D100/R2D101/R2D110

El "Registro de Equipos" está disponible en nuestro sitio web en:
documentation.ifm.com

Australia

English

R1D100/R1D101/R2D100/R2D101/R2D110

These devices comply with the requirements of the relevant ACMA Standards made under the Radiocommunications Act 1992.

Radiodetermination transmitters must not be operated within a nominated distance of a specified Australian radio-astronomy site.

Nominated distance of a specified Australian radio-astronomy site means the following:

(a) in relation to the Parkes Observatory located at latitude 32° 59' 54.25" south, longitude 148° 15' 48.65" east – 10 kilometres of the Parkes Observatory;

(b) in relation to the Paul Wild Observatory located at latitude 30° 18' 46.40" south, longitude 149° 33' 0.44" east – 10 kilometres of the Paul Wild Observatory;

(c) in relation to the Canberra Deep Space Communications Complex located at latitude 35° 23' 48.39" south, longitude 148° 58' 44.35" east – 3 kilometres of the Canberra Deep Space Communications Complex.

For additional information and updates please refer to the Radiocommunications (Low Interference Potential Devices) Class License 2015 published by the Australian Communications and Media Authority

Radiofrequency radiation exposure information

Due to radio frequency exposure limits this device should be installed and operated with a minimum distance of 20 cm between the device and the body of the user or nearby persons.

Brasil

Português

R1D102/R1D103/R2D102/R2D103/R2D111

Este equipamento não tem direito à proteção contra interferência prejudicial e não pode causar interferência em sistemas devidamente autorizados.

Chile

Español

R1D102/R1D103/R2D102/R2D103/R2D111

El "Registro de Equipos" está disponible en nuestro sitio web en: documentation.ifm.com

Mexico

Español

R1D100/R1D101/R2D100/R2D101/R2D110

La operación de este equipo está sujeta a las siguientes dos condiciones:

1. Es posible que este equipo o dispositivo no cause interferencia perjudicial.
2. Este equipo o dispositivo debe aceptar cualquier interferencia. Incluyendo la que pueda causar su operación no deseada.

Namibia

English

R1D100/R1D101/R2D100/R2D101/R2D110

The Radio Equipment Type Approval Certificates for approved devices are available at: documentation.ifm.com

New Zealand

English

R1D100/R1D101/R2D100/R2D101/R2D110

These devices comply with the relevant Standards made under the New Zealand Radio Communications Act 1989.

Radiofrequency radiation exposure information

Due to radio frequency exposure limits this device should be installed and operated with a minimum distance of 20 cm between the device and the body of the user or nearby persons.

South Africa

English

R1D100/R1D101/R2D100/R2D101/R2D110

The Radio Equipment Type Approval Certificates for approved devices are available at: documentation.ifm.com