

[Shenzhen Domino GPS Sport Watch User Manual](#)

[Manualsum](#), simplified manuals

Table of Contents

- [Shenzhen Domino GPS Sport Watch User Manual](#)
 - [PRODUCT INTRODUCTION&BUTTON DEFINITIONS](#)
 - [TOUCH SCREEN CONTROL DEFINITIONS](#)
 - [CHARGING](#)
 - [GPS USAGE](#)
 - [GPS USAGE INTERFACE](#)
 - [APP CONNECTION](#)
 - [UNBINDING APP](#)
 - [NOTES](#)

Shenzhen Domino GPS Sport Watch User Manual

Shenzhen Domino GPS Sport Watch User Manual

([2A837-DM56](#))



PRODUCT INTRODUCTION&BUTTON DEFINITIONS

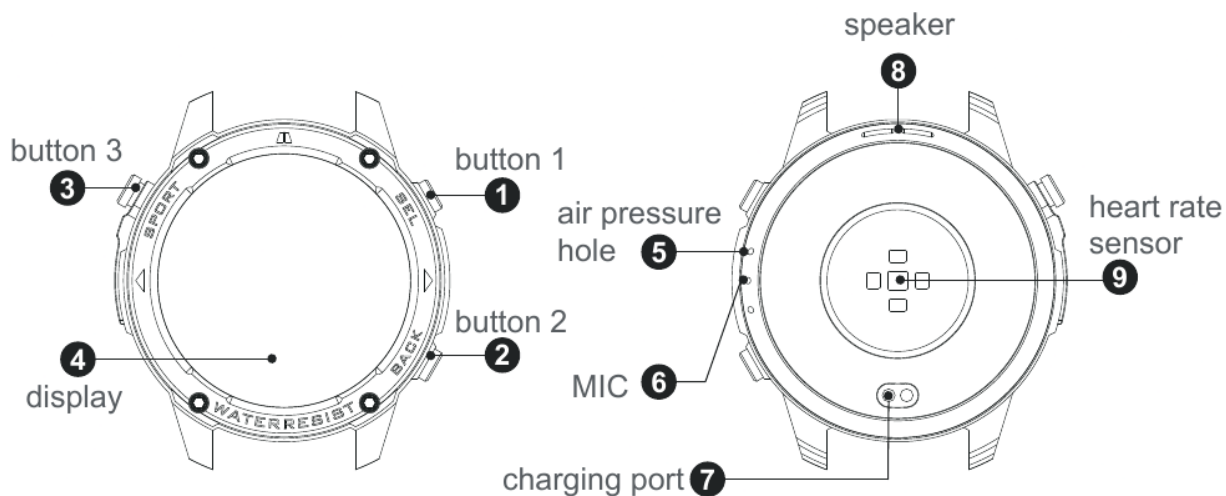

Button (1) definition::

Power button

Short press: Short press once on the watch face interface to turn off the screen.

Short press once on the application list interface to return to the watch face interface. Short press once again to turn off the screen.

Long press for 2s: power on/off, restart, SOS (long press to display menu selection).

Press and hold for 12 seconds: force restart the device.

Button (2) definition:

Return key/shortcut key:

Short press:

- **A.** Other pages return to the previous level/customized shortcut functions.
- **B.** Short press while the screen is idle to light up the screen.
- **C.** Pause/continue during exercise.
- **D.** Short press when there is an incoming call to mute.

Press and hold for 2 seconds: Open the voice assistant/custom shortcut function.

Supplement: Customers can choose one of the return key/shortcut key. If the shortcut function is not set, short press to return to the previous level, and long press the voice assistant. If the shortcut function is set, follow the setting items to achieve it.

Definition of button (3) (sports button):

Short press:

- **A.** Enter the sports mode list
- **B.** Short press to light up the screen when the screen is off
- **C.** Long press for 2S during sports; stop and end the sports

Note: Water sports refer to water sports such as swimming, diving, rafting, rowing, sailing, etc. In this mode, to prevent accidental touches by water drops, the touch function will be turned off by default during sports, and button operation will be preferred. You can also control it by unlocking the touch function.

Key definition in water sports mode:

Button (1): Short press to unlock the touch function. After unlocking, if the interface has been flipped down, you can flip the page up through “button (1)”.

Button (2): Short press to pause the current sports mode. Short press again to continue the current sports and lock the touch screen.

Button (3): Short press to flip the page down, long press to end the sports mode. (If the sports duration is too short, no data will be recorded. When the pop-up window prompts whether to end, short press “button” to continue the sports. Short press “button (2)” to exit the sports.)

TOUCH SCREEN CONTROL DEFINITIONS

- On the watch face interface, press and hold the watch face for 2-3 seconds to switch watch faces. Swipe left or right to switch watch faces, and click to select a watch face.

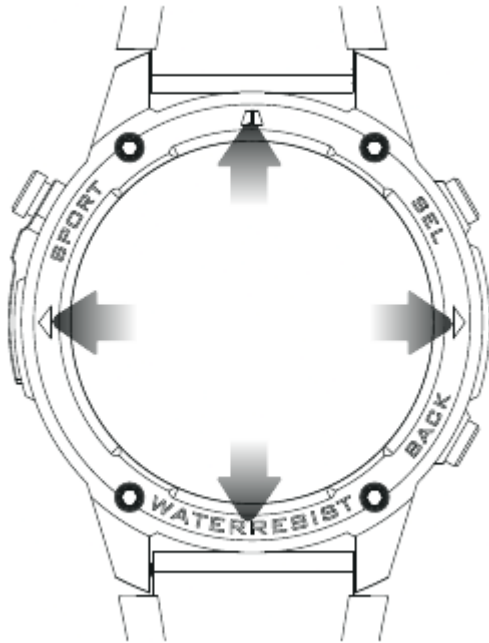

Swipe down: Swipe down on the watch face interface to open the status bar

Swipe up: Swipe up on the watch face interface to access the card shortcut function

Swipe left: Swipe left on the watch face interface to enter the main menu interface

Swipe right: Swipe right on the watch face

CHARGING

1. When the watch prompts that the battery is low, please charge it in time. The charging time is 2-3 hours.
2. The watch is magnetically charged. Align the charging contacts of the charging cable to the charging port of the watch to charge until the watch screen displays the charging prompt.
3. When charging, in order to ensure stable charging, the watch will turn off the screen to charge. Click the button to wake up the watch. When the battery of the watch is too low, it takes 3-5 minutes to wake up the watch. This is normal. Please wait for 5 minutes before checking the charging status of the watch.
4. Please use a charger with a rated output voltage of 5V and a rated output current of 0.5A-2A or a computer USB port to charge the watch.
5. When the watch is not used for a long time, please fully charge it and turn it off for storage. Do not store it for a long time in a low-power state. To avoid damaging the battery due to long-term low-power storage.

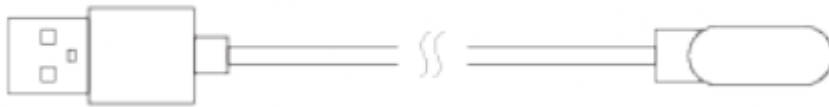

GPS USAGE

1. In order to get a better experience, please connect and bind the APP when using the GPS function for the first time. Within about 3 minutes after binding, the “GloryFitPro” app will send GPS ephemeris orbit and other data to the watch via Bluetooth in the background. After the ephemeris is successfully sent, the GPS positioning time can be greatly shortened. If the sending is not successful, the watch will pop up the “AGPS has expired” reminder when you open the sports with GPS function for the first time. AGPS expiration will cause the positioning time to be too long, affecting the positioning experience. You can try to unbind and bind the watch APP again. And wait for 2 minutes before trying to use the GPS function. If APGS is sent successfully, the “AGPS has expired” reminder will not pop up when you open the GPS function for the first time.
2. At 09:00 every morning, the “GloryFitPro” app will re-acquire the latest GPS ephemeris data of the day. The watch obtains the latest GPS ephemeris data when Bluetooth is connected.
3. The GPS positioning time is too long and whether the GPS track drifts are greatly affected by environmental factors. Choosing an open place or away from high-rise buildings will help GPS to quickly locate and reduce the deviation of the track.
4. Save the data after the exercise, and the APP will synchronize the exercise data. The exercise trajectory and exercise data can be queried in detail on the APP.

GPS USAGE INTERFACE



AGPS has expired



No Location



Get location



Sports with location

APP CONNECTION

Scan the watch QR code or go to major application markets to download and install the "GloryFitPro" APP. When you open the APP for the first time, a permission pop-up window will pop up. Please click "Allow" to ensure that the APP can obtain the corresponding permissions.

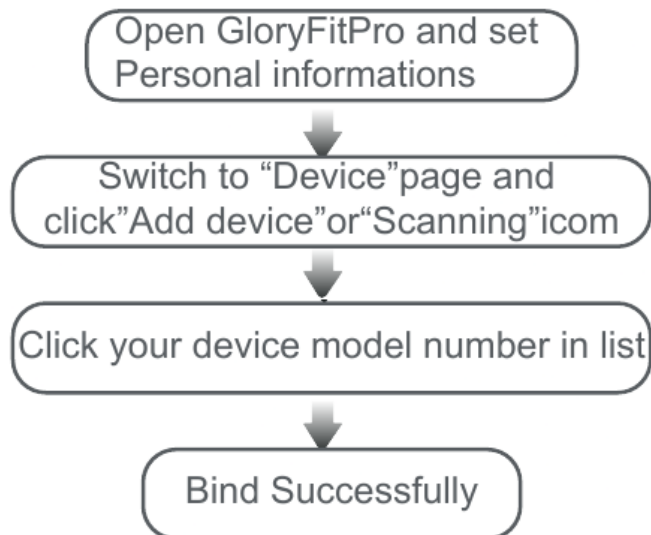

During the connection process, a pop-up window will pop up to confirm the pairing connection with the watch and mobile phone. Please click to confirm the pairing. After the connection is successful, the call icon and data connection icon in the watch status bar will turn green. In gray, it is not connected.



BT Call and APP
Disconnected



APP Connected
BT Call Disconnected



APP Connected
BT Call Connected

UNBINDING APP

IOS: Find "Unbind" in the "Device" interface of the APP and click on it to enter the "Settings-Bluetooth" interface of the mobile phone system. Click on the ! on the right of the device and select "Forget this device" to unbind it from the mobile phone system. Make sure it is no longer connected to the mobile phone, otherwise it will not be able to connect again next time.

Android: Find "Unbind" in the "Device" interface of the APP and click on it to disconnect from the mobile phone

NOTES

1. Prohibit charging in the case of water damage.

2. This device is not a medical device, the data and information provided are for reference only.
3. Hot water shower or sauna etc. can not be worn to prevent water vapor intrusion. If the watch is damaged by water ingress due to use not according to the instructions, we will not provide free warranty.
4. Do not place the device in direct sunlight, such as car dashboard or window sill.
5. Do not place the device close to heat sources or naked flame sources, such as induction cookers, microwave ovens, ovens, water heaters, stoves, candles, or other places where high temperatures may be generated.
6. Please do not allow children or pets to swallow or bite the equipment or its accessories, so as not to cause injury to them or lead to equipment failure.
7. This equipment is not a toy, children should use the equipment under adult supervision.
8. This device is equipped with a non-removable built-in battery, please do not replace the battery by yourself.
9. If the watch has been in contact with water, after leaving the water source, please dry the water stains on the watch surface in a timely manner. If there is too much residual water stains in the sound chamber of the speaker and it is not discharged in time, the sound effect may be affected. Please find the sound hole of the speaker and shake out the residual water in the sound cavity in time.

Shenzhen Domino GPS Sport Watch User Manual