

M30X Series UHF RFID Module User Manual

Manualsum, simplified manuals

Table of Contents

- [M30X Series UHF RFID Module User Manual](#)
 - [Module Specification | M-301 UHF RFID MODULE](#)
 - [Product View](#)
 - [Module Dimensions \(unit: mm \)](#)
 - [Kit Dimensions \(unit: mm \)](#)
 - [Module Specification | M-302 UHF RFID Module](#)
 - [Product View](#)
 - [Module Dimensions \(unit: mm \)](#)
 - [Kit Dimensions \(unit: mm \)](#)
 - [Module Specification | M-303 UHF RFID Module](#)
 - [Product View](#)
 - [Module Dimensions \(unit: mm \)](#)
 - [Kit Dimensions \(unit: mm \)](#)
 - [Module Specification | M-304 UHF RFID Module](#)
 - [Product View](#)
 - [Module Dimensions \(unit: mm \)](#)
 - [Kit Dimensions \(unit: mm \)](#)
 - [Module Specification | UHF RFID Module](#)
 - [PIN Connector Pin Assignments](#)
 - [Electrical Characteristics](#)

M30X Series UHF RFID Module User Manual

M30X Series UHF RFID Module User Manual

([2AKQD-M-302](#))

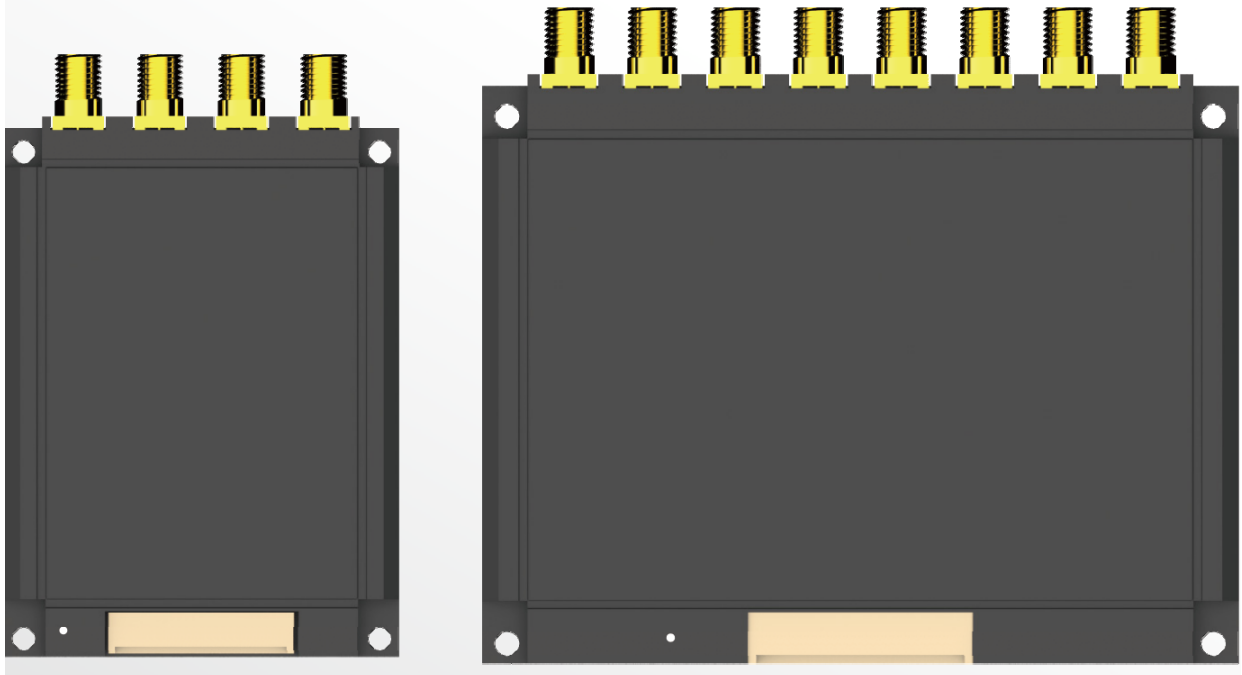

Module Specification | M-301 UHF RFID MODULE

Product View

<p>M-301</p> 	<input type="checkbox"/> RF Channel:	Single Channel
	<input type="checkbox"/> RF Connector:	MMCX
	<input type="checkbox"/> Antenna Connection Mode :	Single Antenna
	<input type="checkbox"/> Interface Connector:	FH34SRJ-30S-0.5SH (50)
	<input type="checkbox"/> RF Connectors Material:	Gold-plated brass
	<input type="checkbox"/> PCB Material:	Rogers FR4 gold-plated
	<input type="checkbox"/> Shield Material:	Cupronickel

Module Dimensions (unit: mm)

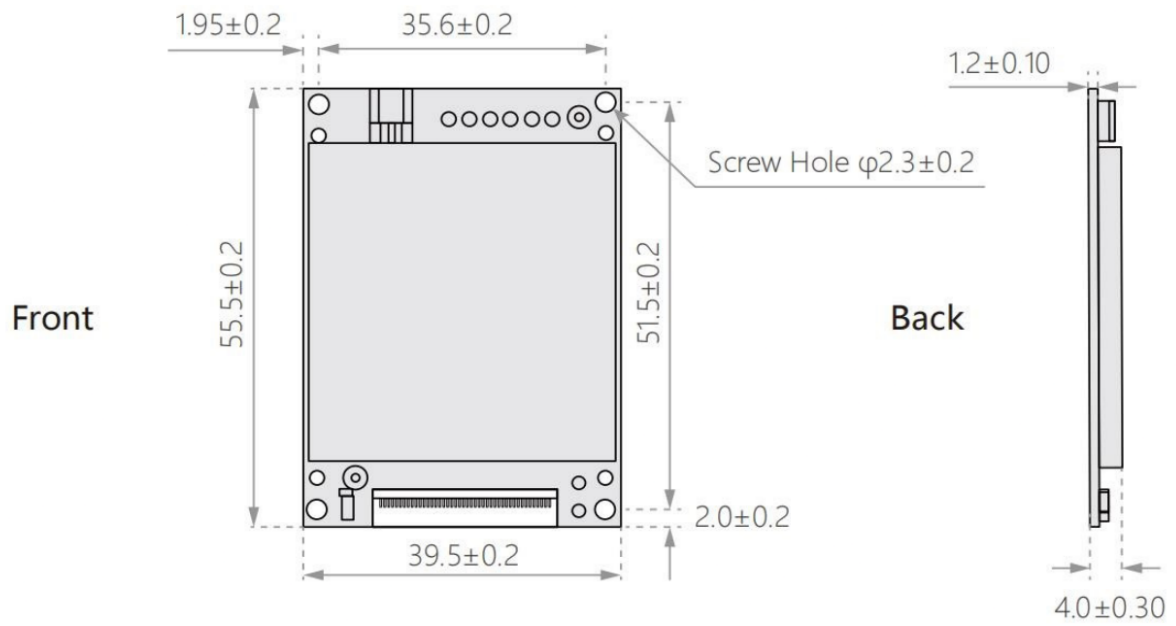

Kit Dimensions (unit: mm)

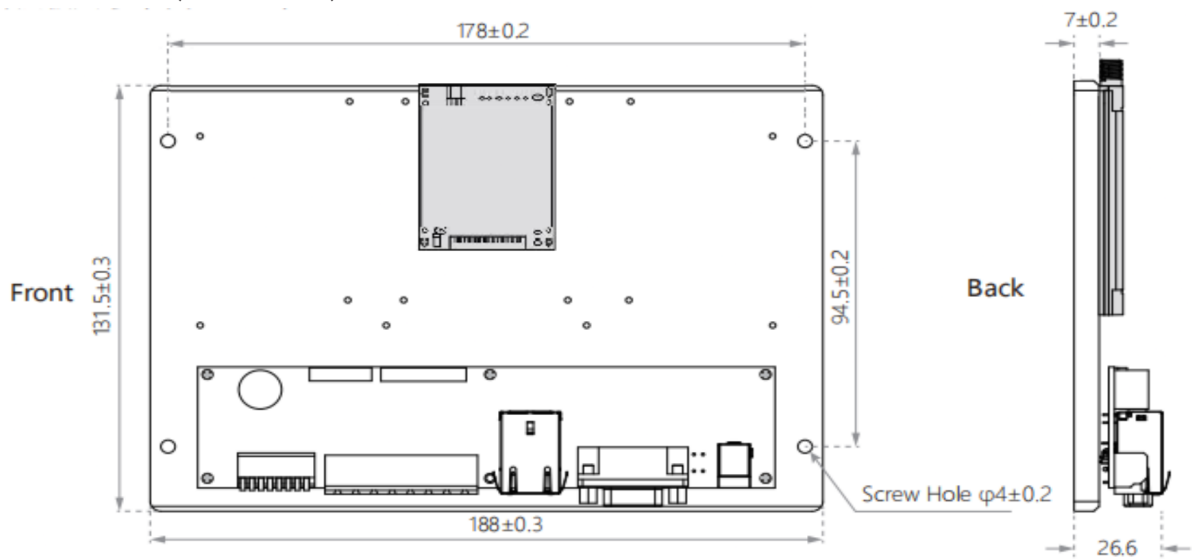

Note: Dimensional drawings are three—dimensional renderings, not physical.

Module Specification | M-302 UHF RFID Module

Product View

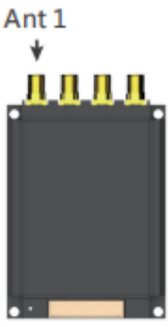
M-302		<input type="checkbox"/> RF Channel:	Four channels
		<input type="checkbox"/> RF Connector:	SMA
		<input type="checkbox"/> Antenna Connection Mode :	Four Antenna
		<input type="checkbox"/> Interface Connector:	Molex 53261-1571
		<input type="checkbox"/> RF Connectors Material:	Gold-plated brass
		<input type="checkbox"/> PCB Material:	Rogers FR4 gold-plated
<input type="checkbox"/> Shield Material:	Aluminum		

Module Dimensions (unit: mm)

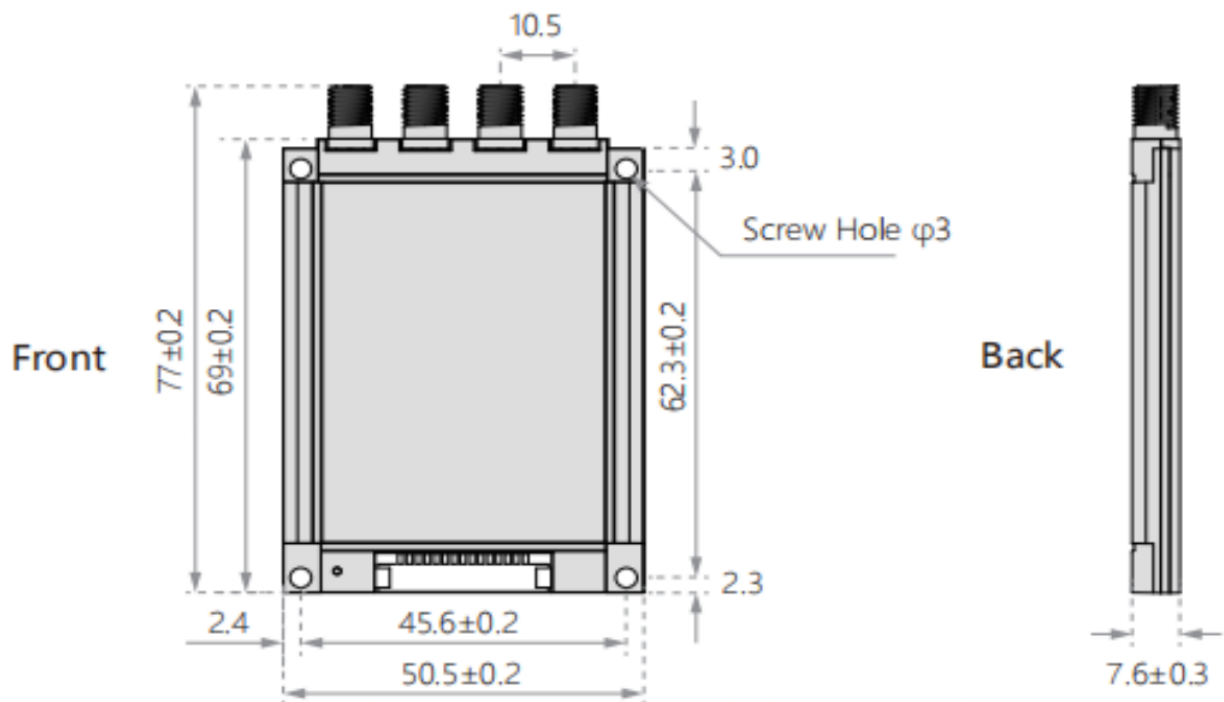

Kit Dimensions (unit: mm)

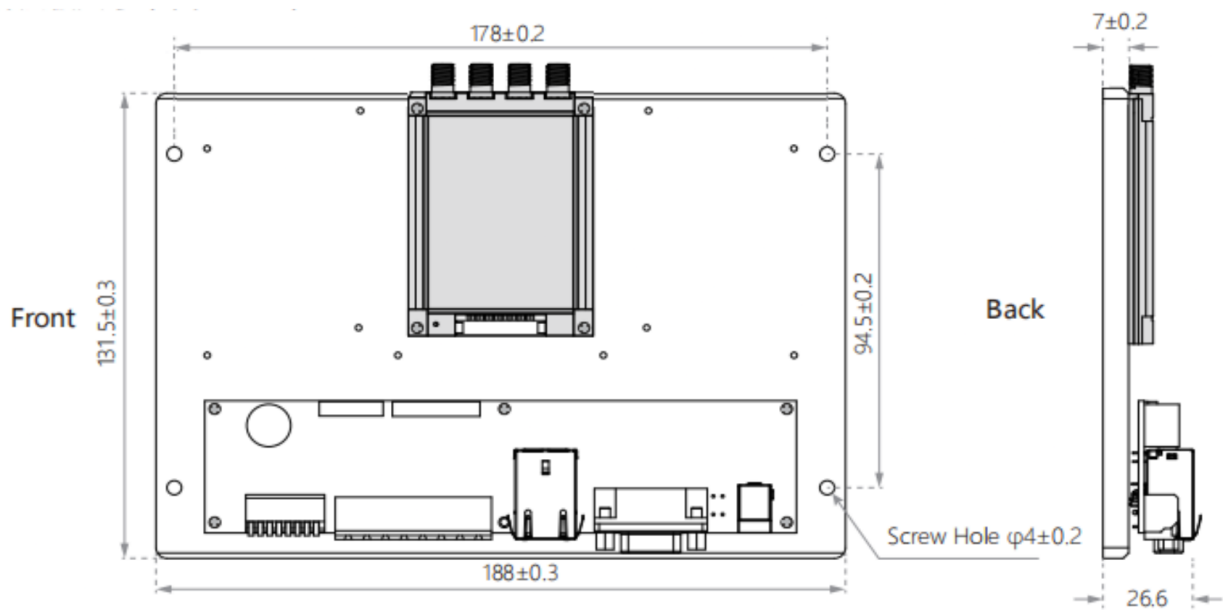

Note: Dimensional drawings are three—dimensional renderings, not physical.

Module Specification | M-303 UHF RFID Module

Product View

M-303		<input type="checkbox"/> RF Channel:	Eight Channels
		<input type="checkbox"/> RF Connector:	SMA
		<input type="checkbox"/> Antenna Connection Mode :	Eight Antenna
		<input type="checkbox"/> Interface Connector:	Molex 53261-1571
		<input type="checkbox"/> RF Connectors Material:	Gold-plated brass
		<input type="checkbox"/> PCB Material:	Rogers FR4 gold-plated
		<input type="checkbox"/> Shield Material:	Aluminum

Module Dimensions (unit: mm)

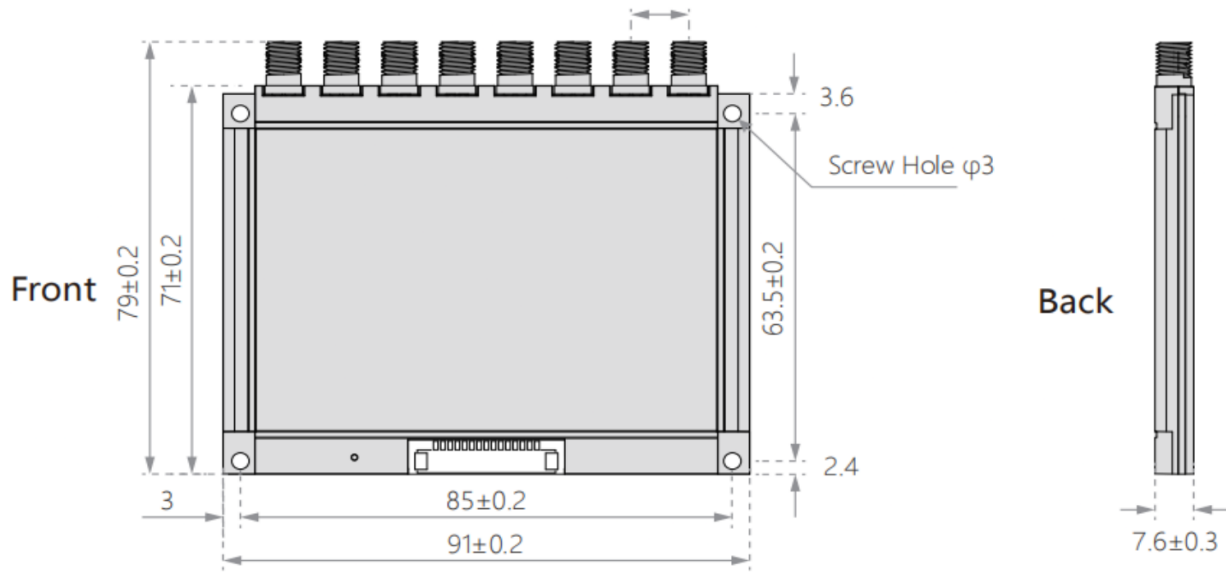

Kit Dimensions (unit: mm)

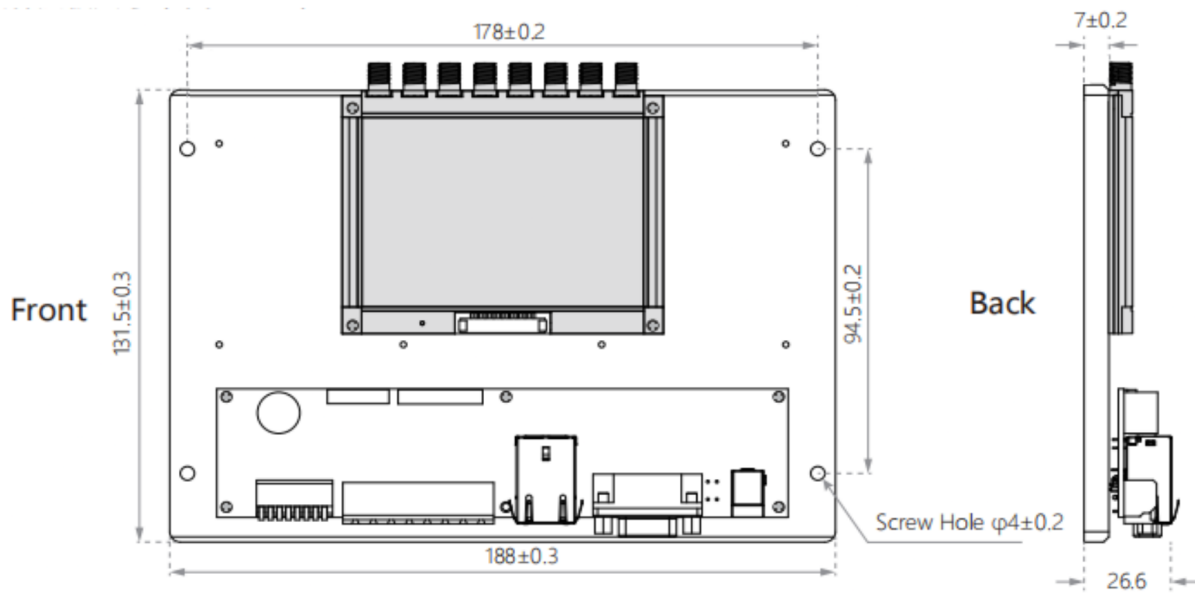

Note: Dimensional drawings are three—dimensional renderings, not physical.

Module Specification | M-304 UHF RFID Module

Product View

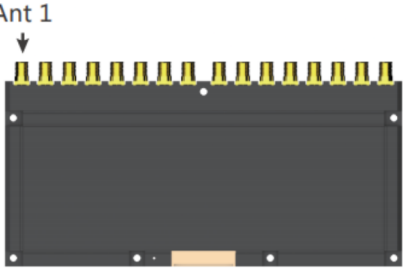
M-304		<input type="checkbox"/> RF Channel:	Sixteen channels
		<input type="checkbox"/> RF Connector:	SMA
		<input type="checkbox"/> Antenna Connection Mode :	Sixteen Antenna
		<input type="checkbox"/> Interface Connector:	Molex 53261-1571
		<input type="checkbox"/> RF Connectors Material:	Gold-plated brass
		<input type="checkbox"/> PCB Material:	Rogers FR4 gold-plated
		<input type="checkbox"/> Shield Material:	Aluminum

Module Dimensions (unit: mm)

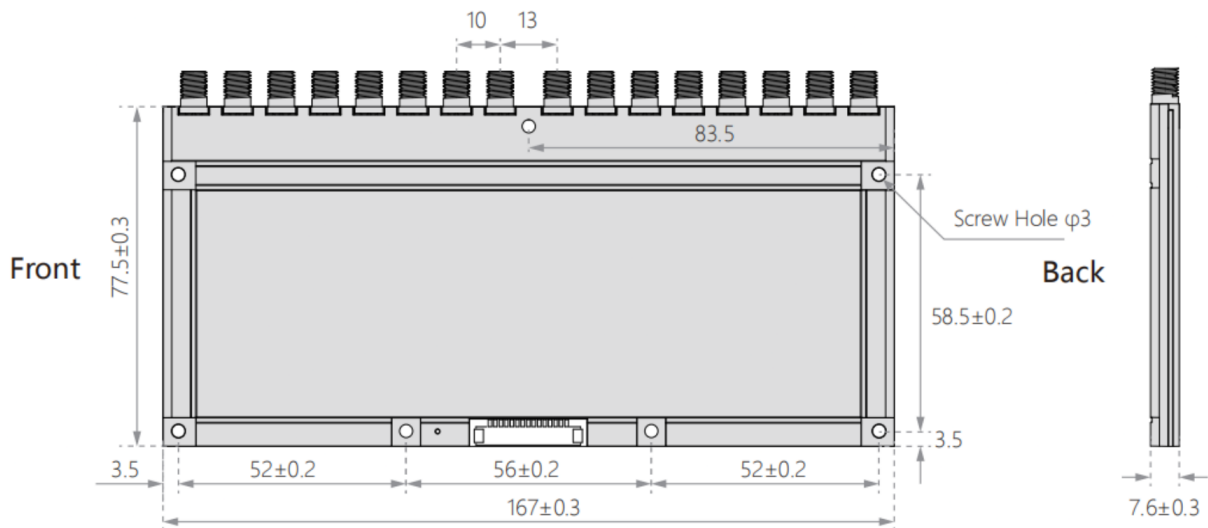

Kit Dimensions (unit: mm)

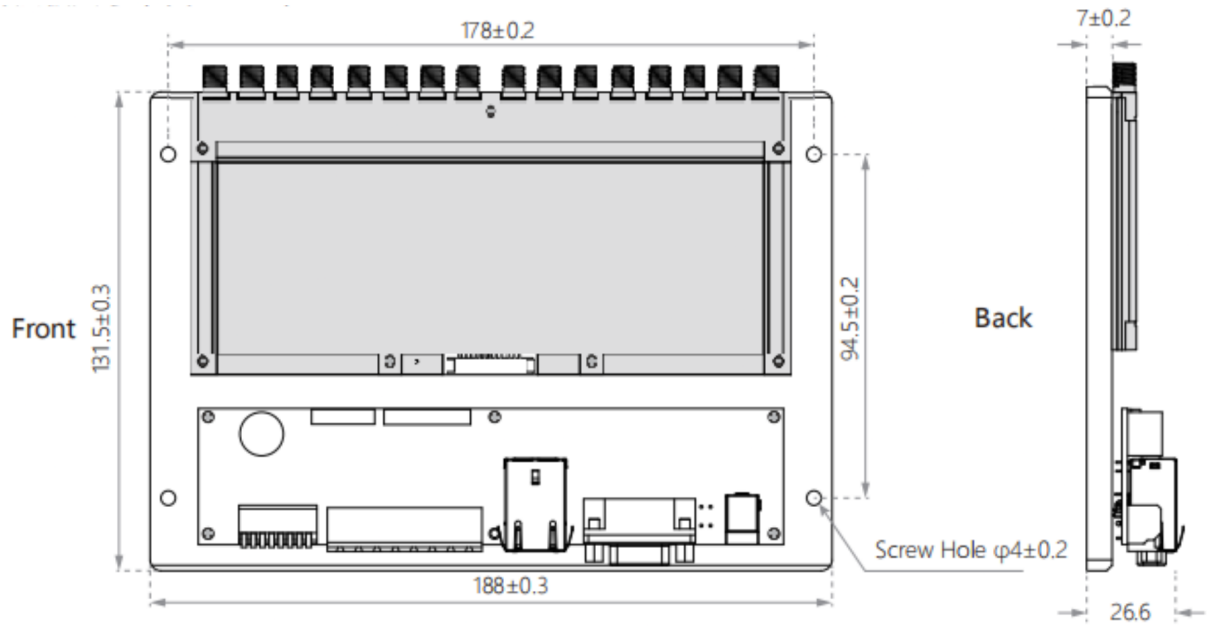

Note: Dimensional drawings are three—dimensional renderings, not physical.

Module Specification | UHF RFID Module

PIN Connector Pin Assignments

PIN Connector Pin Assignments



↑
PIN 1

Connector (15Pin , Space between PINs 1.25mm)

PIN	Interface	Instruction
1	GND	Meanwhile grounding
2	GND	
3	4.5V – 5.5V DC	Meanwhile connect power, Recommended input voltage: 4.6V
4	4.5V – 5.5V DC	
5	GPIO 3	Output
6	GPIO 4	Output
7	GPIO 1	Input
8	Beeper	Has driven with > 50mA output current
9	UART_RXD	TTL level
10	UART_TXD	
11	USB_DM	For testing
12	USB_DP	
13	GPIO 2	Input
14	EN	High level enable
15	GPIO 5	RS-485 direction control

PIN Connector Pin Assignments



FPC connector (30Pin , Space between PINs 0.5mm)

PIN	Interface	Instruction
1	GND	Meanwhile grounding
2	GND	
3	GND	
4	GND	
5	GND	
6	4.5V–5.5V DC	Meanwhile connect power, Recommended input voltage: 4.8V
7	4.5V–5.5V DC	
8	4.5V–5.5V DC	
9	4.5V–5.5V DC	
10	4.5V–5.5V DC	
11	4.5V–5.5V DC	
12	4.5V–5.5V DC	
13	4.5V–5.5V DC	
14	4.5V–5.5V DC	
15	4.5V–5.5V DC	
16	GND	Meanwhile grounding
17	GND	
18	GND	
19	GND	
20	GND	
21	UART_RXD	TTL level
22	UART_TXD	
23	EN	High level enable
24	GPIO1	Input
25	Beeper	Has driven with > 50mA output current
26	GPIO3	Output
27	GPIO4	Output
28	GPIO5	RS-485 direction control
29	GND	Meanwhile grounding

Electrical Characteristics

Electrical Characteristics				
Operating Voltage	4.5V – 5.5V			
Standby Mode Current	50mA (EN high level)			
Sleep Mode Current	<100uA (EN high level)			
Operating Current	Conditions	Min	Type	Max
	@5V(33dbm Output, Multi-tag, 25°C)	300mA	1.3A+-10%	2.5A
Operating Temperature	- 20 °C ~ + 65 °C			
Storage Temperature	- 40 °C ~ + 85 °C			
Humidity	5%RH~95%RH (non -condensing)			
Air Interface Protocol	EPC global UHF Class 1 Gen 2 / ISO 18000-6C			
Spectrum Range	902MHz – 928MHz, 865MHz – 868MHz			
Supported Regions	US, Canada and other regions following U.S. FCC Europe and other regions following ETSI EN 302 208 China , Korea , Malaysia			
Output Power	0 – 33dBm			
Output Power Precision	+/- 1dB			
Output Power Flatness	+/- 0.2dB			
Receive Sensitivity	< -88 dBm			
Peak Inventory Speed	>900 tags/sec			
Tag RSSI	Supported			
Antenna Detector	Supported			
Ambient Temp Monitor	Supported			
Working Mode	Single/DRM			
Host Communication	Uart 3.3V			
GPIO	2 inputs & 2 outputs (3.3V level)			
Max Baud Rate	38400 bps , 115200 bps (Default and recommended), 921600bps			
Heat Dissipation	External radiator			

Note:

- When the temperature, measured by the ambient temperature measurement function, exceeds 60°C, please do not keep the device working at full capacity.
- Please connect the device to heat sink when it continuously work at full load.
- Supply voltage must not exceed 5.5V,otherwise it will damage the internal protection circuit.
- Be cautious if set RF output power over 30dBm, as the peak current and internal temperature will increase significantly.