

# [AiYin Portable Label Printer User Manual](#)

[Manualsum](#), simplified manuals

## **AiYin Portable Label Printer User Manual**

AiYin Portable Label Printer User Manual

(2BDL3-MP231)

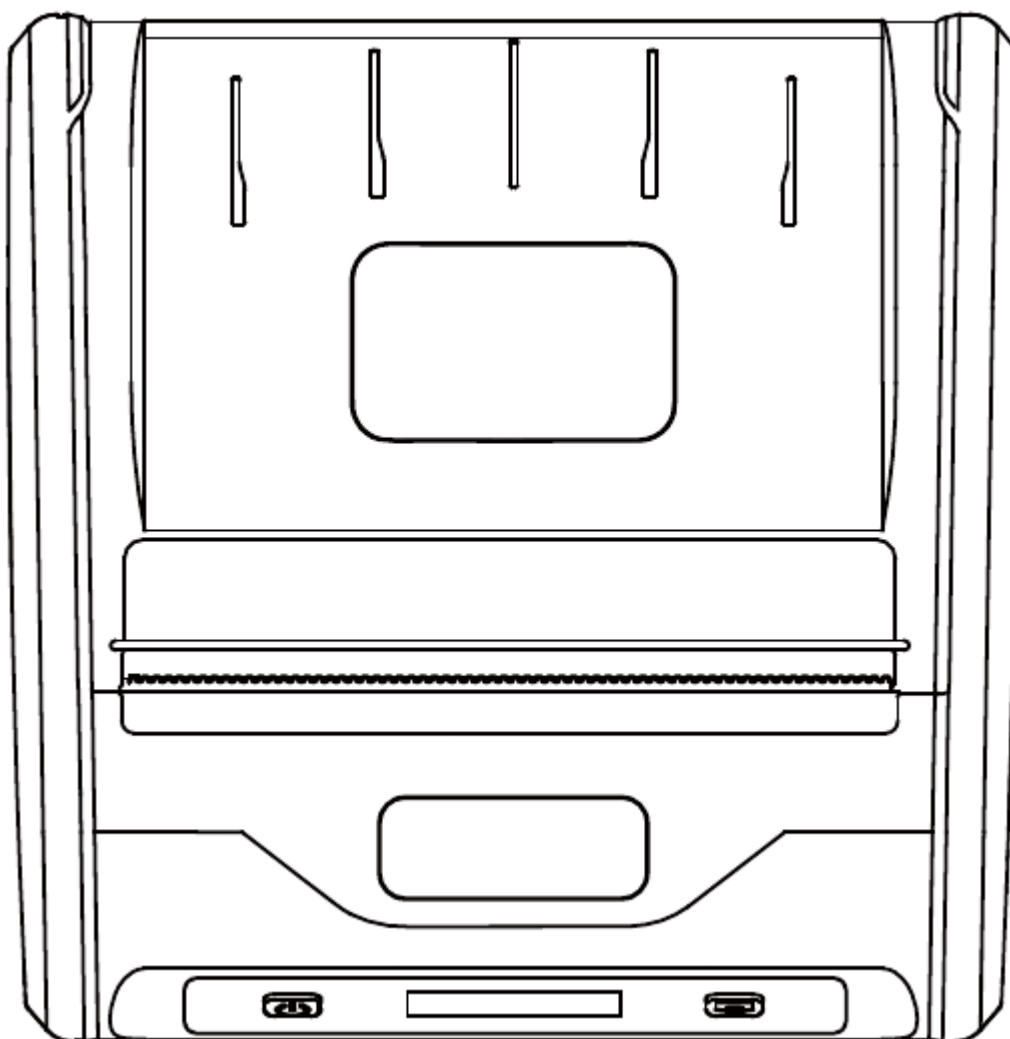

## Packing List

After unpacking, check the appearance of printer, make sure you have all parts. Contact the seller if you found any defective or missing.

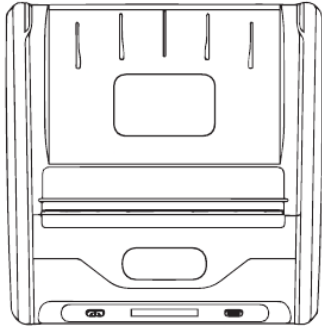

Printer

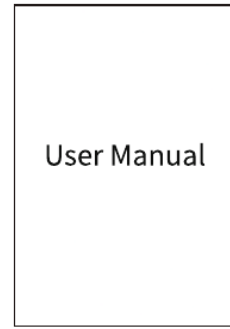

User Manual

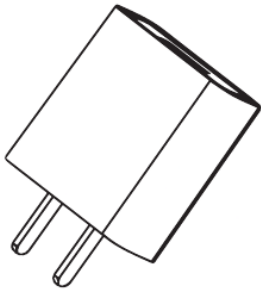

Power Adapter

(Image shown is for illustration purposes only.  
Actual product may vary.)

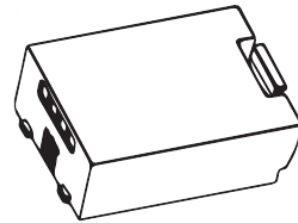

Battery

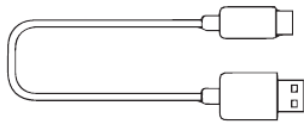

Type-C Cable



**Note**

As the product is improving continuously, all specifications, accessories and programs are subject to practical models. Information in this manual is subject to change without notice.

# Appearance and Components

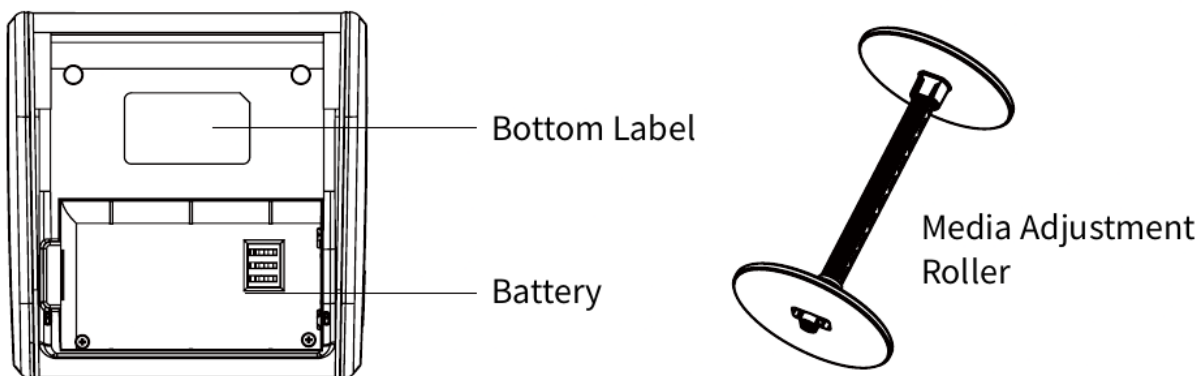
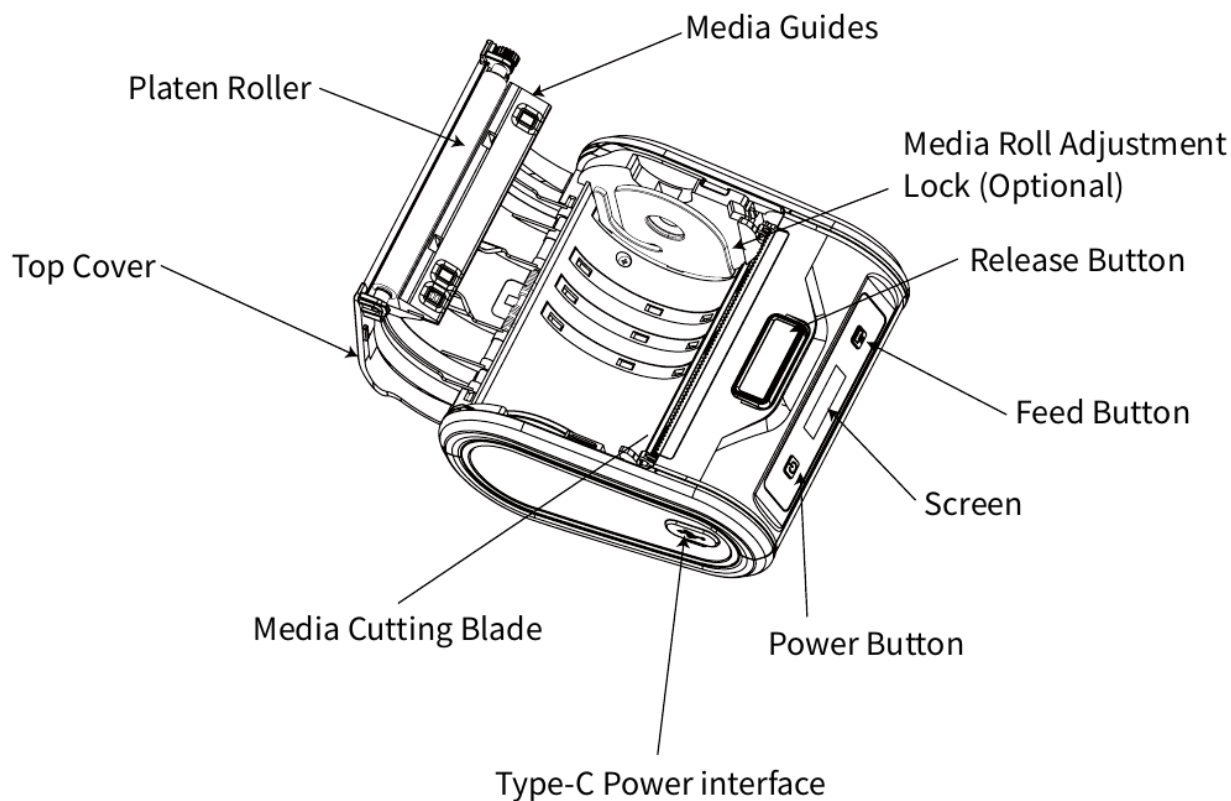

## Battery Installation

### 1. Detaching the battery

Press the battery button to detach the battery (Make sure you turn off the printer before you detach the battery .

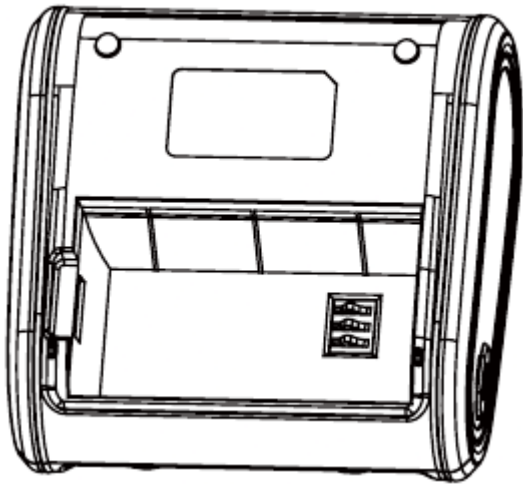

## 2. Attach the battery

Attach the battery per direction of picture. Make sure the electrode is in proper direction.

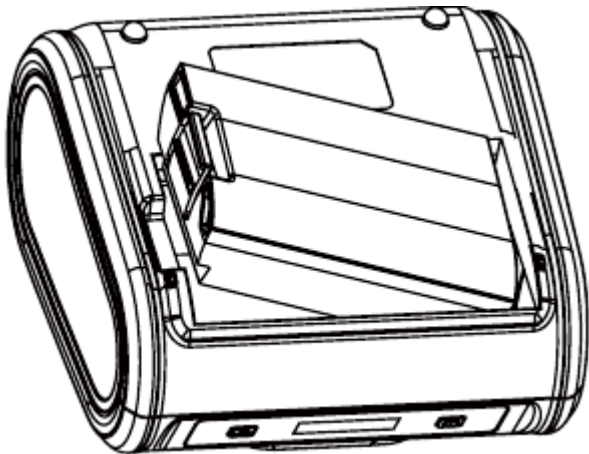

### Caution

1. Please use the battery of right type, otherwise it could result in a potential battery explosion.
2. Make use you dispose the used battery per instructions.

## Printer Charging

Plug the charger into an appropriate AC electrical outlet, insert the Type-C connector of the charger into the printer' s power receptacle.

**AC: 100V~240V (50-60Hz)**

### Warning

Using a charger which is not provided or authorized by our company could result in printer damage.

### Caution

Do not detach the battery while charging.

**Note**

You can conduct printing while charging.

## Loading Roll Media

### 1. Open the top cover

Press "OPEN" button to release the cover.

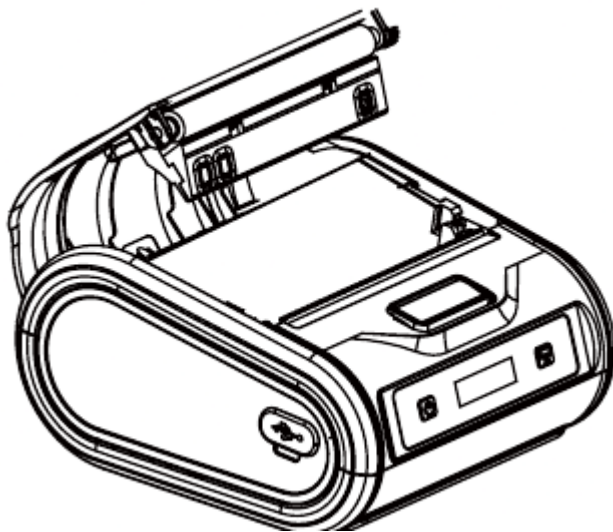

### 2. Loading roll media

Remove the seal and load the roll media into the printer per direction as Picture A (Make sure you load it in the proper direction)

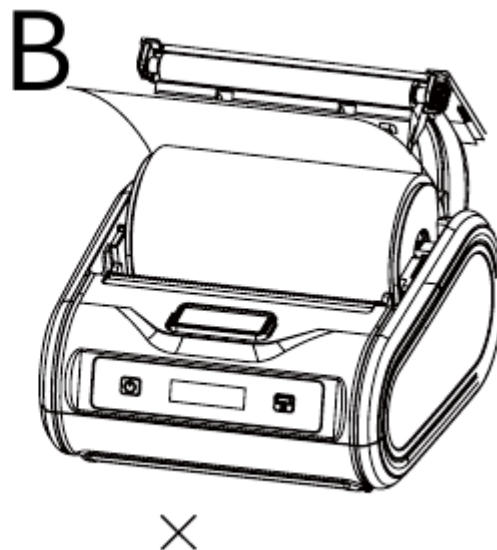
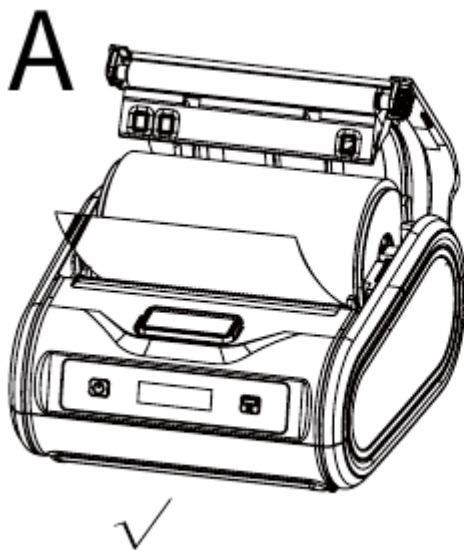

### 3. Close the top cover

The roll media and cutting blade should align.

Then close the top cover.

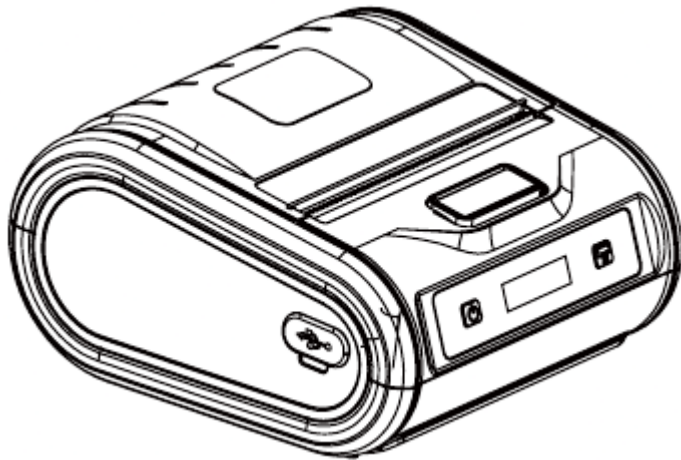

## Basic Functions Instruction

### Press power button to turn on the printer

Standby mode: Press power button and feed button simultaneously for 3 seconds, it switches into menu mode.

#### Menu mode:

1. Press power button to switch the menu items; Press feed button to select item and execute it.
2. Press power button and feed button simultaneously for 3 seconds, it switches into standby mode.

### 1. Printing a test label

You can select and execute “Printing a test label” in the menu mode, then it will print a test label.

### 2. Printing quality

You can select and execute “Printing quality” in the menu mode, then you can choose the printing density ( 1 means lowest; 5 means highest; 3 means neutral.) Press feed button once to confirm the setting. When the setting’s done, there will be a notification of “Succeeded”.

### 3. Adaptability

You can select and execute “Adaptability” in the menu mode, then the printer will adapt the gap per roll media (Make use you use a roll media with gaps).

### 4. Client mode

[Manualsum](#)

You can select and execute “Client mode” in the menu mode, then select a suitable client mode, press the feed button to execute the setting. When the setting’s done, there will be a notification of “Succeeded”. You need to restart the printer after setting, then you can match the printer by Bluetooth.

## **Basic Functions Instruction**

### **5.Dashed solid line**

You can select and execute “Dashed solid line” in the menu mode, then you can select “Open” or “Close” in the submenu (Open mode: the transverse line printed will be the dashed line; Close mode: the transverse line printed will be solid light). Press the feed button to execute the setting. When the setting’s done, there will be a notification of “Succeeded”.

### **6.Hex printing**

This is a special menu item for engineer testing, not for users.

### **7.Feed when closed**

You can select and execute “Feed when closed” in the menu mode, then you can select “Enable” or “Disable” in the submenu ( Disable mode: it won’ t feed when closed; Enable mode: it feeds one plain paper when closed. The default mode is Disable) Press the feed button to execute the setting. When the setting’s done, there will be a notification of “Succeeded”.

### **8.Exit**

You can select and execute “Exit” in the menu mode, then you can exit the menu mode.

### **Note**

You can change the configuration by users’ tools.

### **Cautious**

We appreciate your help in letting us or the sellers know about if there’s anything wrong or missing of the information listed in this manual.

## **Bluetooth Connecting and Usage**

### **1.For mobile phones of Android**

1. Step 1: Turn on the printer;
2. Step 2: Search device in Bluetooth interface, select the printer and connect. The original password is 0000 or 1234. When the Bluetooth pairing’s done, turn on Bluetooth mode per picture;
3. Step 3: Open the APP.



## 2.For mobile phones of iOS

1. Step 1: Turn on the printer and Bluetooth.
2. Step 2: Open the APP, link the printer and print.

## Troubleshooting

Trouble status	Reason	Resolution
The screen shows "The media is out"	There' s no media in the printer	Load media in a proper way
No print on the label	The wrong side of the media is facing up	Load media with the opposite side facing up
The printed image is vague	The printhead is dirty	Clean the printhead
	The media being used is not qualified for colors	Use a right printing density or change another qualified media.
The screen shows "Close the top cover"	Top cover is not properly closed	Close the top cover in a proper way
The printed image becomes vague within a very short time	The media being used is not qualified	Use qualified thermal media with longer retention time
	The storage temperature of printed image is way too high	Keep the printed image in room temperature (Around 20 °C)
The printer close automatically	It runs out of battery	Charge the printer immediately

### Note

Use unqualified media could result in vague printed image in short time.

## Maintenance

### Printer daily maintenance

1. Printer Exterior and media path cleaning: Use water dampened cloth to wipe the exterior and interior of printer. Make sure the dampened cloth is wrung out.
2. Components cleaning: Make sure you clean the components in a regular time. The cleaning method is as follow: Use absorbent [Cotton swab](#)

with dehydrated alcohol, to gently wipe the two parts of printer components, which are highlighted by thick lines in the picture below.

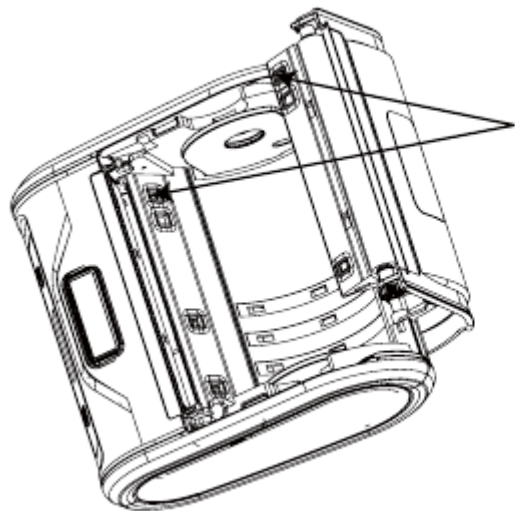

Components and parts

3. If you find the interior of printer gets wet, detach the battery immediately, and dry it up in a ventilated area.
4. If you don' t use the printer for a long period, detach the battery and store it separately.

### **The usage and storage of the printer media**

1. Store the new purchase printer media in a cool place without sunshine. Do not tear off the protection film before you use it.
2. The printed data should be stored in room temperature (Around 20 °C), this could extent the retention period.
3. Use a long retention thermal media if the data needs to be kept for a long time.

## **Product Warranty Card**

Dear customer: Thank you for using our product, since purchase, you have below services: [Free Maintenance]

Since the date of your purchase, product performance failure caused by non-human damage according to the following warranty period:

Product Type	Parts	Warranty Period
Desktop Printer	Whole device (except print head)	1 year
	Print head	3 months or 30 km (whichever comes first)
Portable Printer	Whole device (except print head)	1 year
	Print head	3 months or 30 km (whichever comes first)
Accessories	Battery	1 year
	Power adapter	3 months
	Data cable	3 months

Note: The print head damaged by force majeure factors (including but not limited to scratches, injuries, burns, corrosion, etc.) is not covered by warranty.

## [Paid Maintenance]

In the following cases (including but not limited to), you can choose paid services:

1. No warranty card or missing valid invoice or exceeding the warranty period;
2. No iData mark or illegible product number;
3. Damage caused by failure to use, maintain keep, disassemble or repair the machine in accordance with the requirements of the product manual;
4. Damage caused by customers in using non-authentic(iData) accessories (print head, motherboard, power adapter, data cable, etc.);
5. Normal wear and tear during use of the product;
6. Damage caused by unauthorised service personnels disassembly;
7. The user's own network and software cause the product to be unusable;
8. Damage caused by accident or human factors (operation error, scratch, handling bump, improper input voltage, etc.);
9. Damage caused by improper storage by users, or loss of product parts (rodent, insect pest, liquid infiltration, foreign matter entry and other similar reasons);
10. Damage caused by force majeure such as natural disaster (earthquake, fire, etc.).

**Note:** Required accessories for repairing are valid for a 1 year after the product discontinued

## After-sale Service

**Service Email:** sales@idataglobal.com or contact the salesman/local dealer/authorized repair station

**Official Website:** [www.idataglobal.com](http://www.idataglobal.com)

Head Office Address: Floor 11, Building B1, Wuxi(Binhu) National Sensing Information Center, N0.999 Gaolang East Road Wuxi

City, Jiangsu Province, P.R.C

2022©@ WUXI IData TECHNOLOGY COMPANY LTD. reserves the right of final interpretation of this warranty and conditions.

## AiYin Portable Label Printer User Manual