

# [BoldHue User Manual](#)

## [Manualsum](#), simplified manuals

### Table of Contents

- [BoldHue User Manual](#)
  - [Safety Instructions](#)
    - [Use](#)
    - [Handling](#)
    - [Repairing](#)
    - [Battery](#)
    - [Charging](#)
    - [Magnetic Interface](#)
  - [Getting Started.](#)
    - [What You Need](#)
    - [Unboxing and Preparing Your System](#)
    - [Unboxing Steps and Preparing Your System](#)
    - [Scanning Skin for Your Custom Foundation](#)
    - [Dispensing Your Custom Foundation Shade](#)
  - [Cleaning and Maintenance.](#)
    - [After Each Use](#)
    - [Monthly](#)
    - [Reusing the Jar](#)
    - [Cartridge Status](#)
  - [Error Screens.](#)
    - [Missing Wand](#)
    - [Replace Cartridge](#)
    - [Close Drawer](#)
    - [Missing Jar](#)
    - [Low Cartridge](#)
    - [Dispensing Error](#)
  - [Environmental Responsibility.](#)

## **BoldHue User Manual**

BoldHue User Manual

ZOBELE Instrument BoldHue User Manual

FCC id: [2AURX-BOLDHUE](#)

[Manualsum](#)



**BOLDHUE**

IMPORTANT: For best user experience, open the mobile app and follow the prompts. Scan here to download the app.



## Safety Instructions

Do not apply to broken skin. If product enters the eye, flush with water until you experience relief. Keep away from children. For external use only.

Failure to follow these safety instructions could result in fire, electric shock, injury, or damage to device or other property.

INSTRUCTIONS PERTAINING TO A RISK OF FIRE, ELECTRIC SHOCK, OR INJURY TO PERSONS.

Read all the safety information below before using this device.

When using electrical devices, especially when children are present, basic safety precautions should always be followed, including the following:

### Use

This device should never be left unattended when plugged in. Close adult supervision is necessary when this device is used by, on, or near children or individuals with certain disabilities. To avoid danger of suffocation, keep the cartridge caps, jar lid, and small accessories out of the reach of children. The device and cartridges should be stored out of reach of children under 3 years old. Use this device only for its intended use as described in this manual. Avoid eye area when applying the product. Only use authorized parts and accessories with the BoldHue device. Do not use modified or counterfeit cartridges. BoldHue will not be responsible for damage, injury or poor product performance caused by use of any other refills or unapproved replacement parts in this device.

### Handling

Handle your BoldHue device with care. The device or its battery can be damaged if dropped, burned, punctured, or crushed, or if it's exposed to water. If you suspect there is damage to device or battery, stop using the device, as it may cause overheating or injury. To reduce the risk of electrical shock, do not put the device in water or other liquid.

Do not place or store the device in proximity of water.

## **Repairing**

Do not open device and do not attempt to repair device yourself. The disassembling of the device unit or the cartridges voids the warranty. For maintenance refer to the attached instructions. Disassembling device may damage it or may cause injury. If device is damaged or malfunctions, contact BoldHue support. Repairs by service providers other than BoldHue may not involve the use of BoldHue genuine parts and may affect the safety and functionality of the device.

## **Battery**

Do not attempt to replace the battery yourself: the device battery should only be repaired by a trained technician to avoid battery damage, which could cause overheating, fire, or injury. Do not use the device if the battery is damaged or modified: it may exhibit unpredictable behavior resulting in fire, explosion or risk of injury. Do not expose the battery or device to temperature above 130°C/265°F as it may cause an explosion.

## **Charging**

Charge device with the included cable. The recharge of the battery shall be done at a temperature between 10°C (50°F) and 40°C (104°F). Using damaged cables or chargers, or charging when moisture is present, can cause fire, electric shock, injury, or damage to device or other property. Never operate this device if it has a damaged cord or plug, if it is not working properly, or if it has been dropped, damaged, or dropped into water. Do not use an extension cord with this device.

## **Magnetic Interface**

BoldHue device contains magnets. Pacemakers, defibrillators and credit cards may be affected by magnetic fields. For safety reasons avoid placing them near the mentioned items.

# Getting Started.

## What You Need

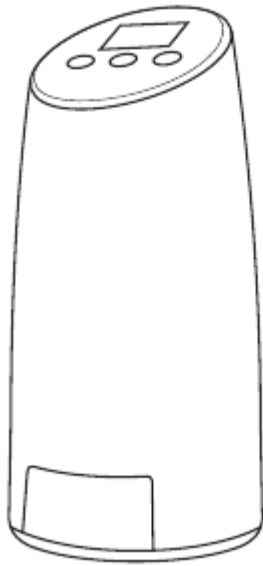

The BoldHue™ device

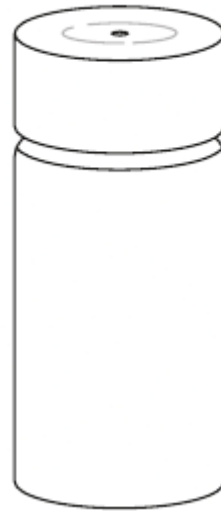

Six cartridges with caps, one of each of the following: red, yellow, blue, white, black,



Jar with cap and ring

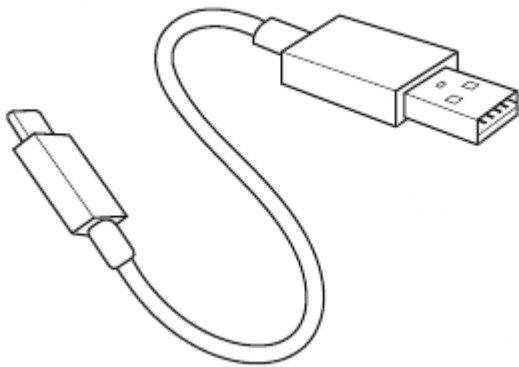

USB cord

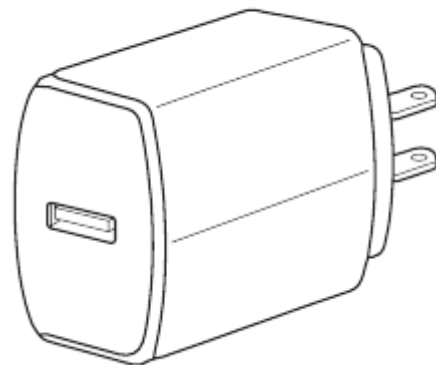

USB power adapter (**not provided**)



A smartphone

- The smartphone should comply with the following minimum technical requirements:
- iPhone: minimum iPhone 6 (or later generations) with iOS 15 or above
- Android: Android 8.0 with Bluetooth 4.2 or higher

Inside the BoldHue™ Custom Foundation Device box, you will find the following components:

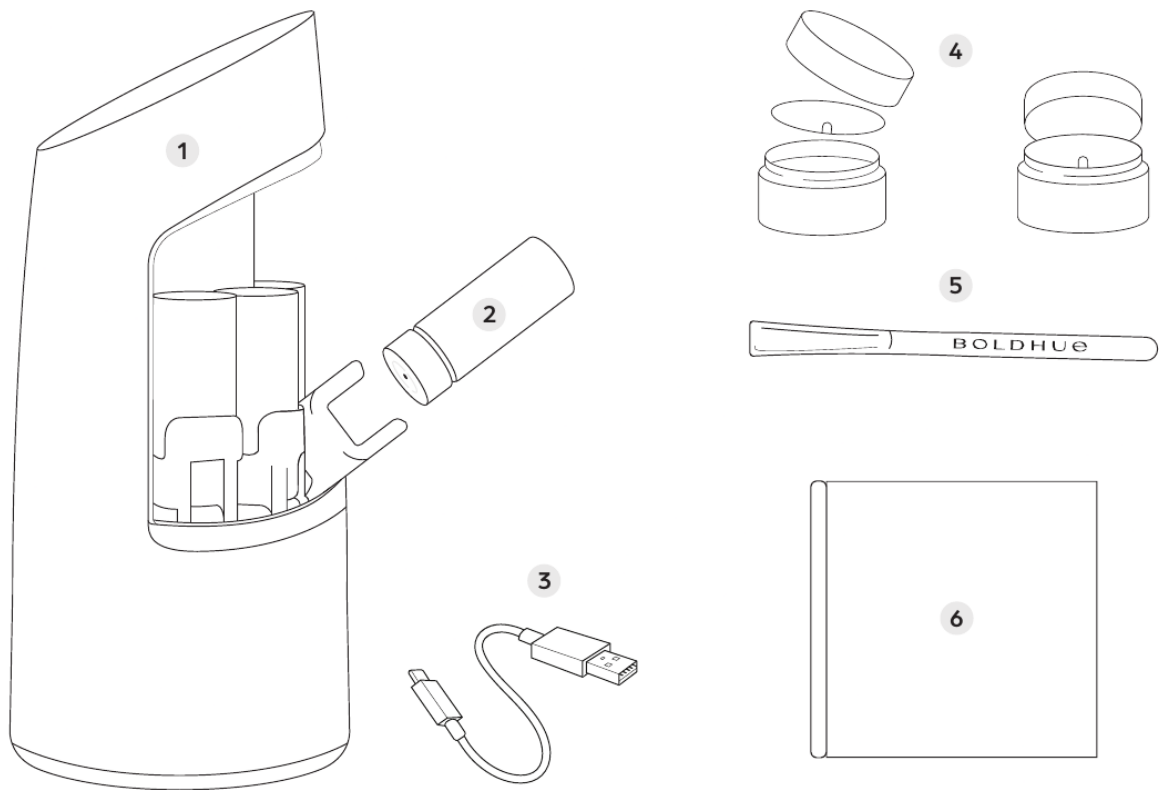

1. The BoldHue™ device
2. 6 cartridges
3. USB cord (**USB power adapter not provided**)
4. 2 empty jars with cap and protective liner disc
5. Mixing spatula
6. User manual

Inside the BoldHue™ Custom Foundation Device and its following components:

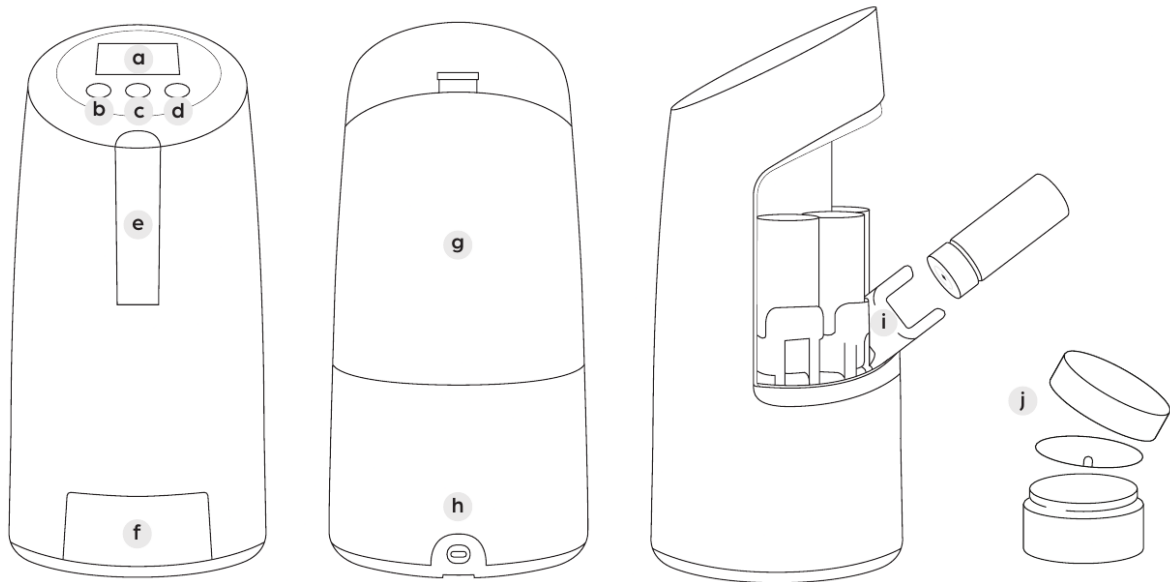

- **a** Device LCD screen
- **b** Left arrow button
- **c** Power button
- **d** Right arrow button
- **e** Scanning wand
- **f** Device drawer
- **g** Power port
- **h** Device back panel
- **i** Device cartridge holders
- **j** Jar, protective liner disc

## Unboxing and Preparing Your System

### Scan the QR Code

Your device will not operate without completing the following process. Scan

QR code and follow the instruction video tutorial directions for use, or

follow the  
instructions  
below.





## Unboxing Steps and Preparing Your System



1

Carefully remove the device from the box. Place upright on a flat, stable surface.

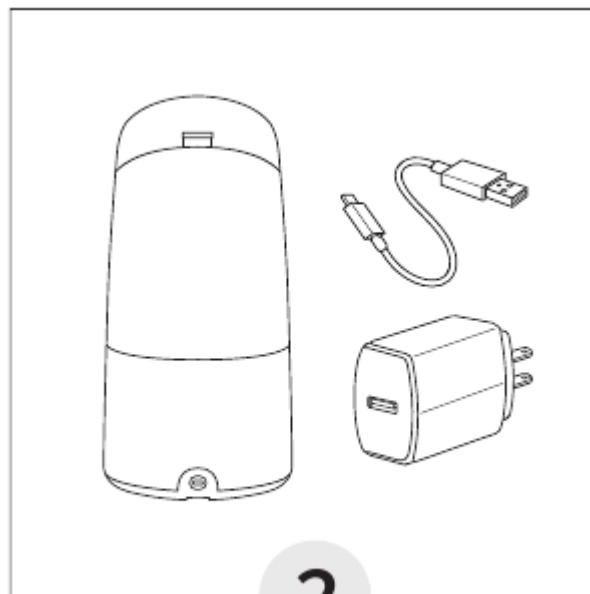

2

Connect the device to the USB cable with USB power adapter (not included) to power the device.



Power

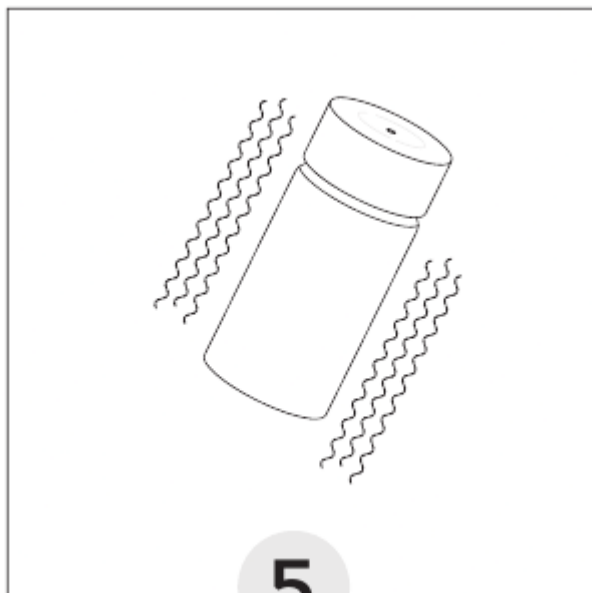

5

Remove individual cartridges from their cartons. Shake vigorously.



6

Remove caps.

**IMPORTANT: Keep your caps for future use.**

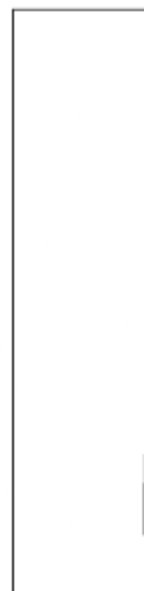

In the cartridge approx

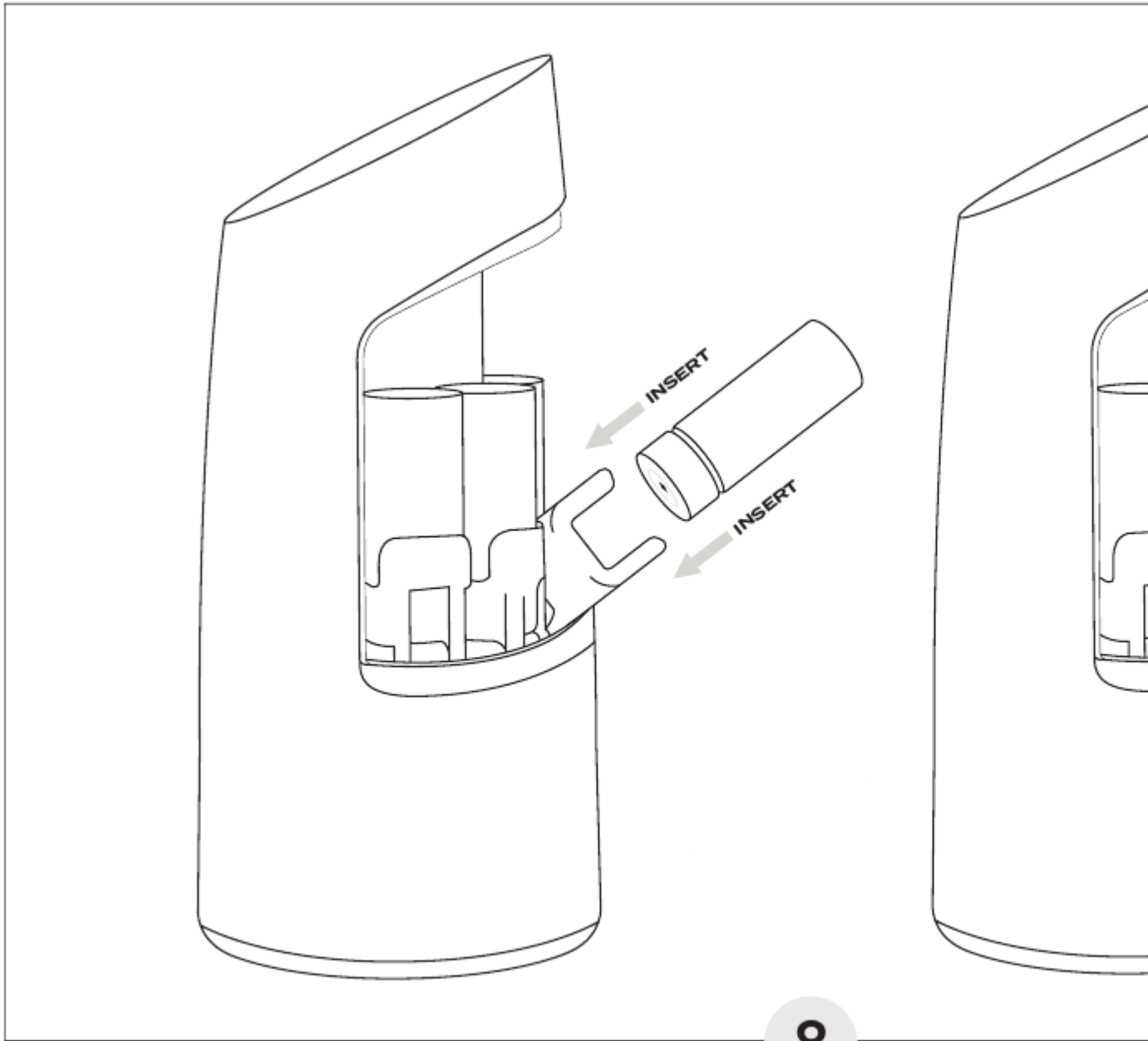

8

Turn one cartridge upside down and insert into the corresponding colored cartridge punctured. Turn the cartridge clockwise until you hear or feel one click indicate

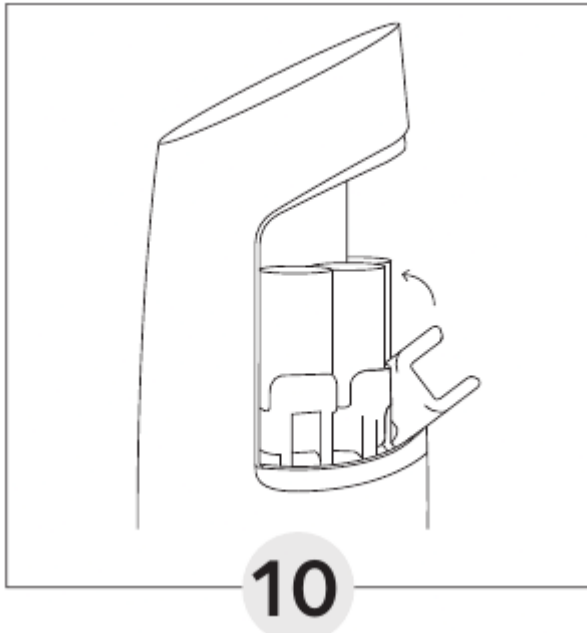

Return cartridge holder to upright position.

## Scanning Skin for Your Custom Foundation

**Important: For best user experience, open the mobile app and follow the prompts.**

When not using the app, follow the steps below:

**1**

Press the power button (b) to turn the device on.

If the device does not turn on, or is not fully charged, connect it to the USB cable (2) with USB power adapter (not included) to power the device.

**4**

After completing three scans and receiving three vibration confirmations, return the wand back to the cradle in device so that it snaps into place.

2

As directed in the instruction video tutorial, place the glass end of the wand (c) flat against your skin, ensuring it makes full contact but only with gentle pressure.

5

The scan results will be displayed on the LCD screen

(1). To accept and proceed push the right arrow button (f), to rescan push the left arrow button (g)

3

When vibration is felt, remove wand from skin. Complete this step a total of three times always waiting for the vibration as an indicator that the scan has been successful.

## Dispensing Your Custom Foundation Shade

1

Unpack one empty jar (4) from the carton. Be sure to remove cap and protective liner (1i).

**IMPORTANT: Unscrew cap before insertion and remove the protective liner disc and set aside.**

6

Close the drawer until you hear a click, indicating the drawer is fully closed.

2

When the device drawer (h) opens, place the uncapped jar in the drawer and push until it hits the bottom entirely.

7

Press the middle power button (a) until the device turns off.

3

Close the drawer until you hear a click, indicating the drawer is fully closed. Once the drawer is closed, the device will automatically begin dispensing. (This will take a few minutes.)

8

Use the enclosed spatula (5) to stir the makeup in the jar until it is evenly blended and no streaks of color remain. Your foundation is ready to apply as desired.

[Manualsum](#)

4

When finished, the screen will indicate that dispensing is complete.

9

After use, replace protective liner disc and lid on jar.

5

When dispensing is complete, the drawer will open. Remove the jar from the device.

## Cleaning and Maintenance.

### After Each Use

Wipe the glass end of the scanning wand (1c) using a cotton pad or clean tissue.

Unplug before cleaning. Do not rinse or submerge the wand in water.

### Monthly

To ensure the best formulation experience:

- Take all the cartridges out of the device and set them upright on a surface.

Cartridge nozzles may have excess formulation that can stain porous surfaces if contact occurs.

- Apply saved caps to each of the cartridges and shake each vigorously. DO NOT SHAKE WITHOUT COVERING ORIFICE, pigment will spill or splash hitting unwanted surfaces.
- If caps have been discarded, cover the cartridge orifice using the likes of a tissue, cotton round, etc. Refrain from using finger.
- Remove caps and replace each cartridge in its matching color cartridge holder (1e).

### Reusing the Jar

To reuse the jar for the next match, clean the jar, liner disk and cap with a makeup remover or gentle soap.

Allow to fully dry.

## Cartridge Status

The mobile app provides monitoring on the status of each of your cartridges, including:

- Cartridge expired
- Lowfilllevel
- Cartridge empty

## Error Screens.

### Missing Wand

The device requires that the wand be in place on the device to continue with the match process.

- Place the wand so the device housing is flush with the wand body.
- If the error continues, remove and wipe the wand housing with a cotton pad or clean tissue and reinsert.

### Replace Cartridge

The device has sensed that a cartridge is missing or empty. Follow instructions for the installing cartridges.

### Close Drawer

The device has sensed that the drawer is not closed. Close drawer until a click is heard.

### Missing Jar

The jar is required for the match to be made.

- Place the jar in the drawer and ensure it is fully inserted.
- Close drawer until a click is heard.

### Low Cartridge

The device has sensed that a cartridge is running low on formulation. Follow instructions for the installing new cartridges to replace the empty ones as prompted.

### Dispensing Error

If the device alerts you to a sensor error, please contact support for a sensor cleaning tool.

**NOTE:** Support is available through our mobile app or on our website at <http://www.boldhue.com>.

[Manualsum](#)

## **Environmental Responsibility.**

This product is subject to a separate collection of electrical and electronic equipment. At the end of its life, the appliance must be processed separately from household waste. This will prevent any harmful impact on the environment or on human health due to the uncontrolled disposal of waste that can contain dangerous substances.

The user is responsible to return the appliance to a specific center for waste electrical and electronic appliances.

For additional information regarding applicable local laws, please contact your local municipal facility.

For more information, download the app, or visit us at [boldhue.com](https://boldhue.com)